

DATA SHEET

General Magnetic field sensors

1998 Jun 12

File under Discrete Semiconductors, SC17

GENERAL INTRODUCTION

Contents

- Operating principles
- Philips magnetoresistive sensors
- Flipping
- Effect of temperature on behaviour
- Using magnetoresistive sensors
- Further information for advanced users
 - The MR effect
 - Linearization
 - Flipping
 - Temperature compensation.

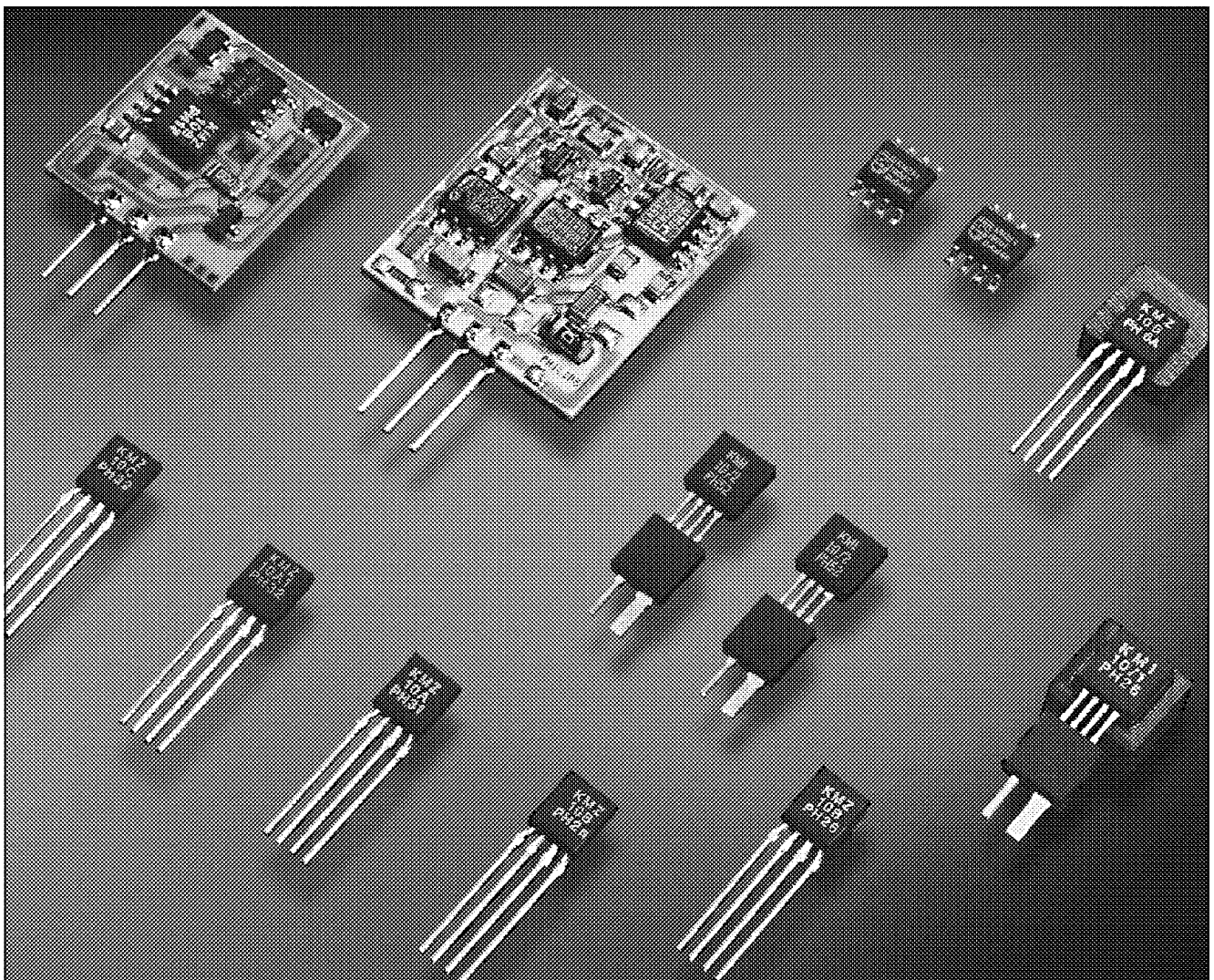

Magnetic field sensors

General

The KMZ range of magnetoresistive sensors is characterized by high sensitivity in the detection of magnetic fields, a wide operating temperature range, a low and stable offset and low sensitivity to mechanical stress. They therefore provide an excellent means of measuring both linear and angular displacement under extreme environmental conditions, because their very high sensitivity means that a fairly small movement of actuating components in, for example, cars or machinery (gear wheels, metal rods, cogs, cams, etc.) can create measurable changes in magnetic field. Other applications for magnetoresistive sensors include rotational speed measurement and current measurement.

Examples where their properties can be put to good effect can be found in automotive applications, such as wheel speed sensors for ABS and motor management systems and position sensors for chassis position, throttle and pedal position measurement. Other examples include instrumentation and control equipment, which often require position sensors capable of detecting displacements in the region of tenths of a millimetre (or even less), and in electronic ignition systems, which must be able to determine the angular position of an internal combustion engine with great accuracy.

Finally, because of their high sensitivity, magnetoresistive sensors can measure very weak magnetic fields and are thus ideal for application in electronic compasses, earth field correction and traffic detection.

If the KMZ sensors are to be used to maximum advantage, however, it is important to have a clear understanding of their operating principles and characteristics, and how their behaviour may be affected by external influences and by their magnetic history.

Operating principles

Magnetoresistive (MR) sensors make use of the magnetoresistive effect, the property of a current-carrying magnetic material to change its resistivity in the presence of an external magnetic field (the common units used for magnetic fields are given in Table 1).

Table 1 Common magnetic units

1 kA/m = 1.25 mTesla (in air)
1 mT = 10 Gauss

The basic operating principle of an MR sensor is shown in Fig.2.

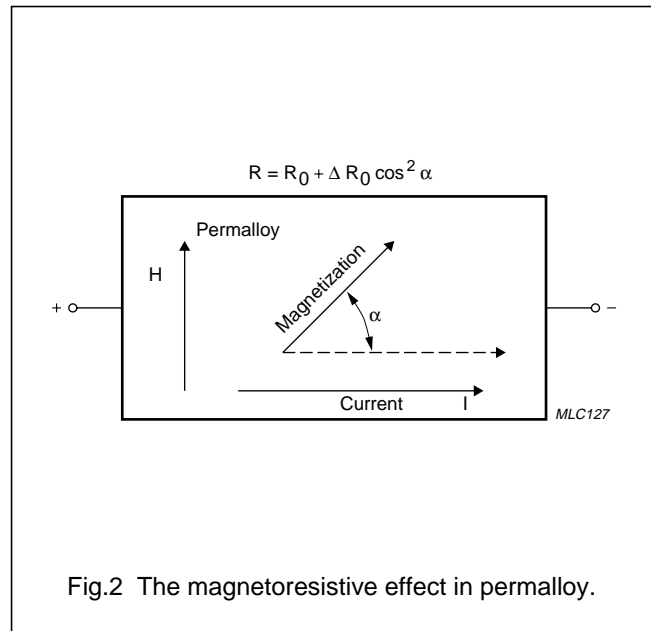

Fig.2 The magnetoresistive effect in permalloy.

Figure 2 shows a strip of ferromagnetic material, called permalloy (20% Fe, 80% Ni). Assume that, when no external magnetic field is present, the permalloy has an internal magnetization vector parallel to the current flow (shown to flow through the permalloy from left to right). If an external magnetic field H is applied, parallel to the plane of the permalloy but perpendicular to the current flow, the internal magnetization vector of the permalloy will rotate around an angle alpha. As a result, the resistance of R of the permalloy will change as a function of the rotation angle alpha, as given by:

$$R = R_0 + \Delta R_0 \cos^2 \alpha \tag{1}$$

R₀ and ΔR₀ are material parameters and to achieve optimum sensor characteristics Philips use Ni19Fe81, which has a high R₀ value and low magnetostriction. With this material, ΔR₀ is of the order of 3%. For more information on materials, see Appendix 1.

It is obvious from this quadratic equation, that the resistance/magnetic field characteristic is non-linear and in addition, each value of R is not necessarily associated with a unique value of H (see Fig.3). For more details on the essentials of the magnetoresistive effect, please refer to the Section "Further information for advanced users" later in this chapter or Appendix 1, which examines the MR effect in detail.

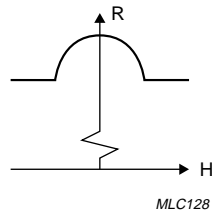

Fig.3 The resistance of the permalloy as a function of the external field.

In this basic form, the MR effect can be used effectively for angular measurement and some rotational speed measurements, which do not require linearization of the sensor characteristic.

In the KMZ series of sensors, four permalloy strips are arranged in a meander fashion on the silicon (Fig.4 shows one example, of the pattern on a KMZ10). They are connected in a Wheatstone bridge configuration, which has a number of advantages:

- Reduction of temperature drift
- Doubling of the signal output
- The sensor can be aligned at the factory.

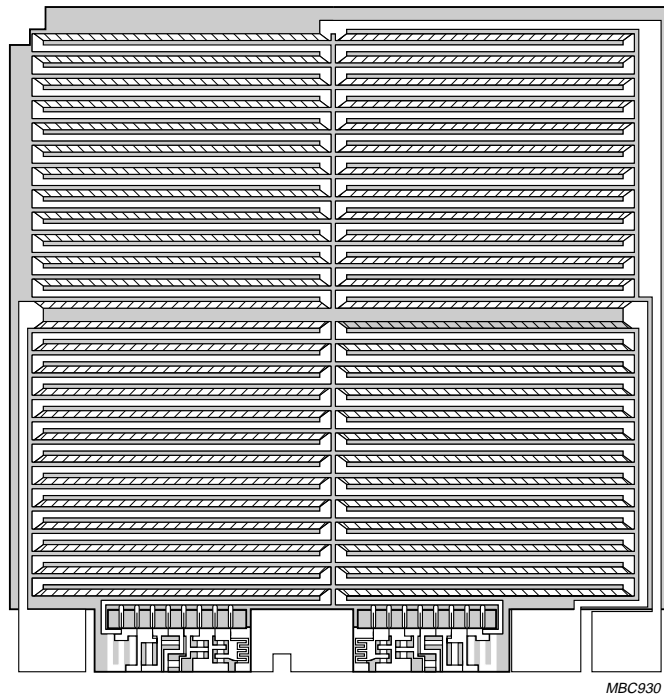

Fig.4 KMZ10 chip structure.

Magnetic field sensors

General

Two further resistors, R_T , are included, as shown in Fig.5. These are for trimming sensor offset down to (almost) zero during the production process.

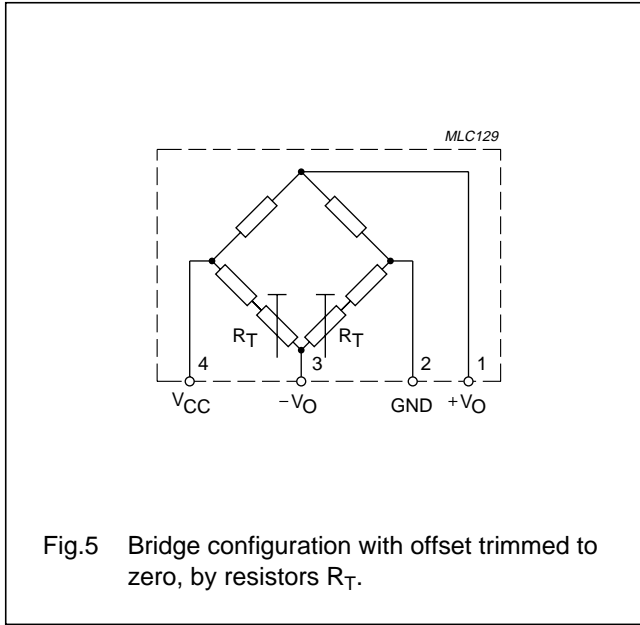

Fig.5 Bridge configuration with offset trimmed to zero, by resistors R_T .

For some applications however, the MR effect can be used to its best advantage when the sensor output characteristic has been linearized. These applications include:

- Weak field measurements, such as compass applications and traffic detection;
- Current measurement; and
- Rotational speed measurement.

For an explanation of how the characteristic is linearized, please refer to the Section "Further information for advanced users" later in this chapter.

Philips magnetoresistive sensors

Based on the principles described, Philips has a family of basic magnetoresistive sensors. The main characteristics of the KMZ sensors are given in Table 2.

Table 2 Main characteristics of Philips sensors

SENSOR TYPE	PACKAGE	FIELD RANGE (kA/m) ⁽¹⁾	V _{CC} (V)	SENSITIVITY (mV/V) / (kA/m)	R _{bridge} (kΩ)	LINEARIZE MR EFFECT	APPLICATION EXAMPLES
KMZ10A	SOT195	-0.5 to +0.5	≤9	16.0	1.2	Yes	compass, navigation, metal detection
KMZ10A1 ⁽²⁾	SOT195	-0.05 to +0.05	≤9	22.0	1.3	Yes	navigation, metal detection, traffic control
KMZ10B	SOT195	-2.0 to +2.0	≤12	4.0	2.1	Yes	current measurement, angular and linear position, reference mark detection, wheel speed
KMZ11B1	SO8	-2.0 to +2.0	≤12	4.0	2.1	Yes	
KMZ10C	SOT195	-7.5 to +7.5	≤10	1.5	1.4	Yes	
KMZ41	SO8	H = 100 ⁽³⁾	≤12	2.8	2.5	No	angular measurement
KMZ50	SO8	-0.2 to +0.2	≤8	16.0	2.0	Yes	compass, navigation, metal detection, traffic control
KMZ51	SO8	-0.2 to +0.2	≤8	16.0	2.0	Yes	

Notes

1. In air, 1 kA/m corresponds to 1.25 mT.
2. Data given for operation with switched auxiliary field.
3. Recommended field strength.

Flipping

The internal magnetization of the sensor strips has two stable positions. So, if for any reason the sensor is influenced by a powerful magnetic field opposing the internal aligning field, the magnetization may flip from one position to the other, and the strips become magnetized in the opposite direction (from, for example, the '+x' to the '-x' direction). As demonstrated in Fig.6, this can lead to drastic changes in sensor characteristics.

The field (e.g. '-H_x') needed to flip the sensor magnetization, and hence the characteristic, depends on the magnitude of the transverse field 'H_y': the greater the field 'H_y', the smaller the field '-H_x'. This follows naturally, since the greater the field 'H_y', the closer the magnetization's rotation approaches 90°, and hence the easier it will be to flip it into a corresponding stable position in the '-x' direction.

Looking at the curve in Fig.7 where H_y = 0.5 kA/m, for such a low transverse field the sensor characteristic is stable for all positive values of H_x and a reverse field of ≈1 kA/m is required before flipping occurs. At H_y = 2 kA/m however, the sensor will flip even at smaller values of 'H_x' (at approximately 0.5 kA/m).

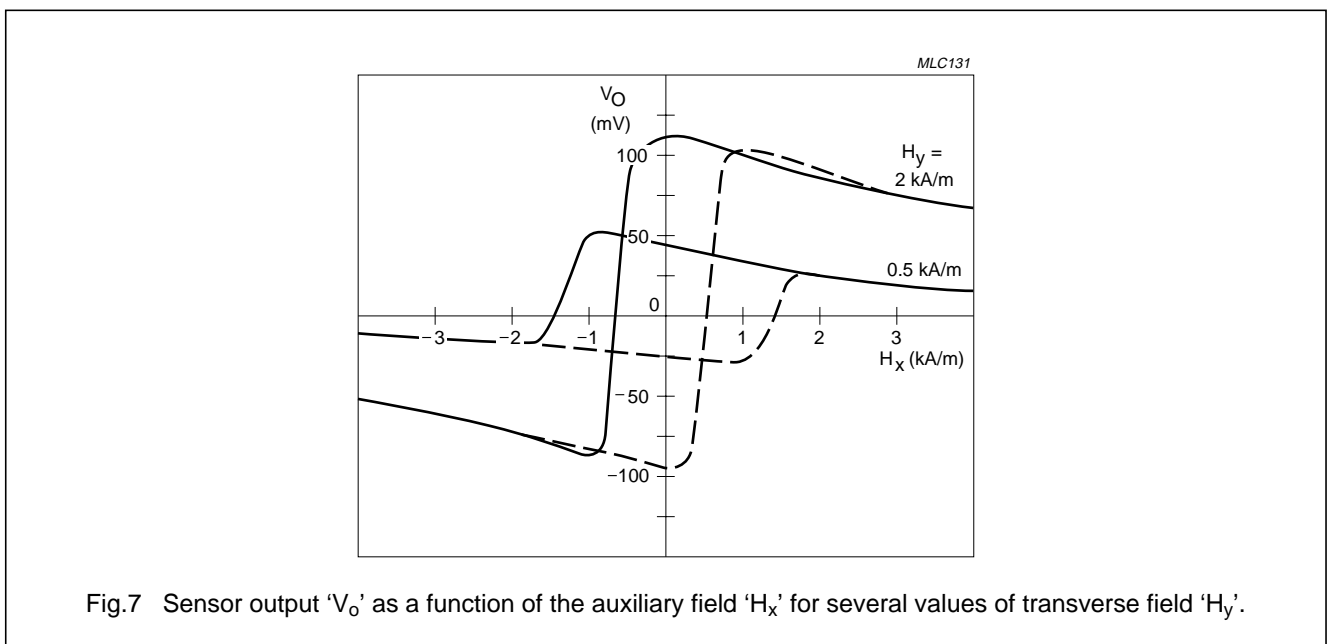
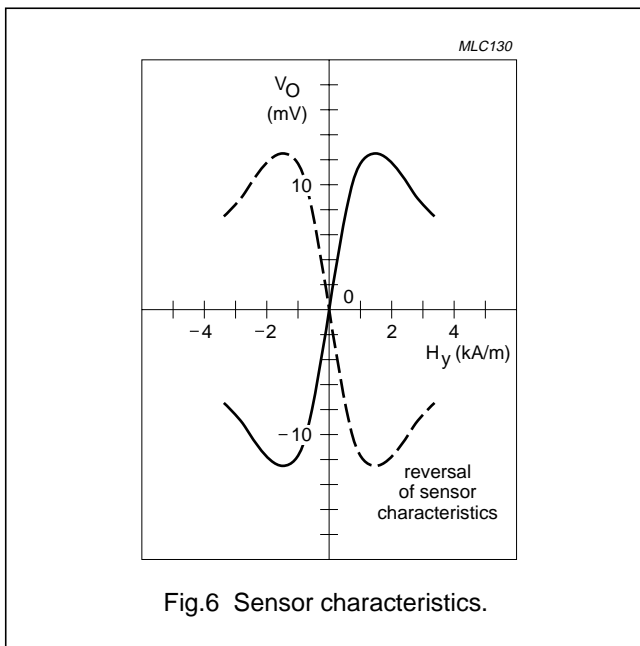

Figure 7 also shows that the flipping itself is not instantaneous, because not all the permalloy strips flip at the same rate. In addition, it illustrates the hysteresis effect exhibited by the sensor. For more information on flipping, see the Section "Further information for advanced users" later in this chapter and Appendix 1 on the magnetoresistive effect.

Effect of temperature on behaviour

Figure 8 shows that the bridge resistance increases linearly with temperature, due to the bridge resistors' temperature dependency (i.e. the permalloy) for a typical KMZ10B sensor. The data sheets show also the spread in this variation due to manufacturing tolerances and this should be taken into account when incorporating the sensors into practical circuits.

In addition to the bridge resistance, the sensitivity also varies with temperature. This can be seen from Fig.9, which plots output voltage against transverse field ' H_y ' for various temperatures. Figure 9 shows that sensitivity falls with increasing temperature (actual values for given for every sensor in the datasheets). The reason for this is rather complex and is related to the energy-band structure of the permalloy strips.

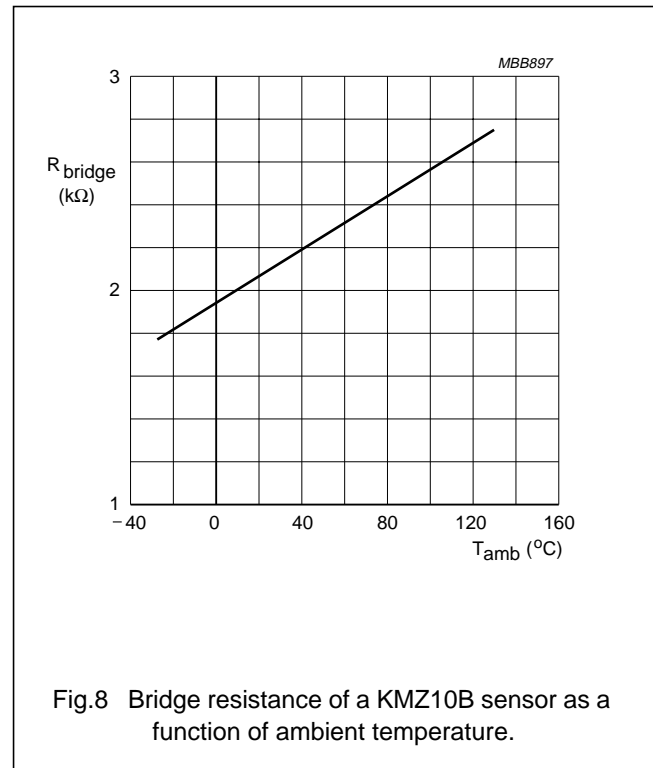

Fig.8 Bridge resistance of a KMZ10B sensor as a function of ambient temperature.

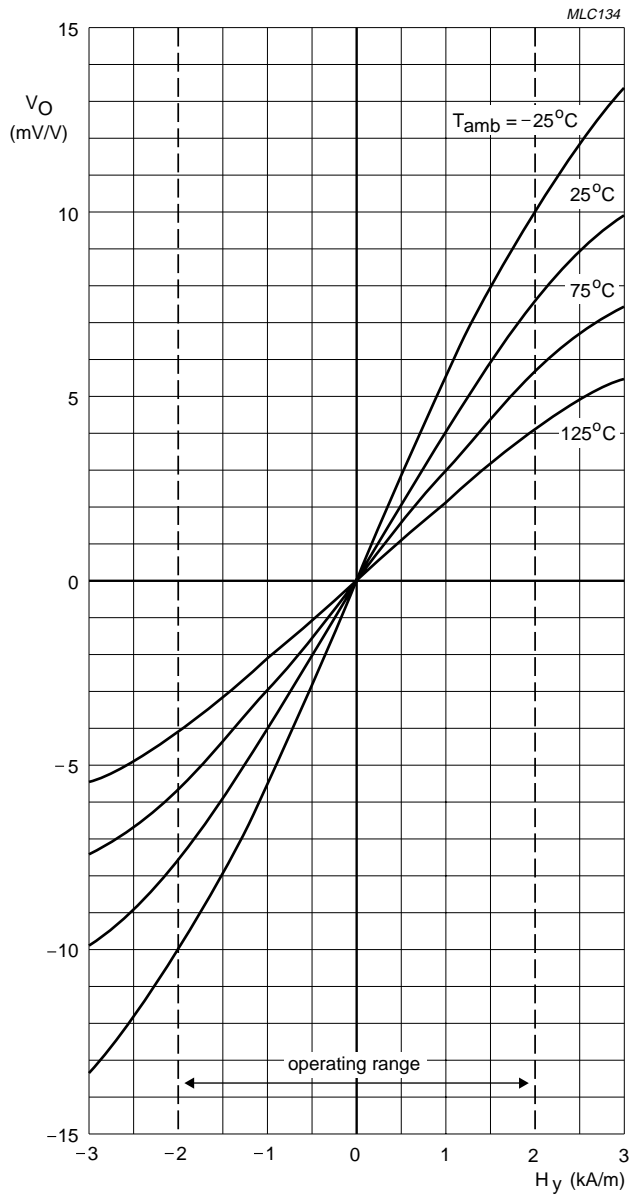

Fig.9 Output voltage ' V_o ' as a fraction of the supply voltage of a KMZ10B sensor as a function of transverse field ' H_y ' for several temperatures.

Magnetic field sensors

General

Figure 10 is similar to Fig.9, but with the sensor powered by a constant current supply. Figure 10 shows that, in this case, the temperature dependency of sensitivity is significantly reduced. This is a direct result of the increase in bridge resistance with temperature (see Fig.8), which

partly compensates the fall in sensitivity by increasing the voltage across the bridge and hence the output voltage. Figure 8 demonstrates therefore the advantage of operating with constant current.

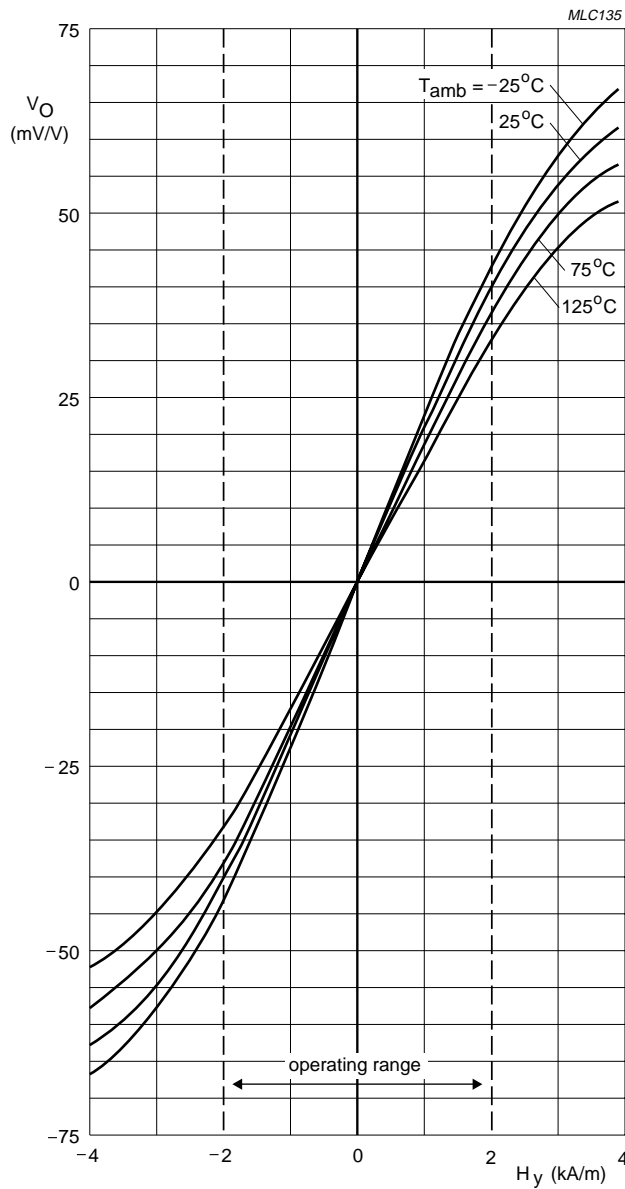

Fig.10 Output voltage 'V_o' of a KMZ10B sensor as a function of transverse field 'H_y' for several temperatures.

Using magnetoresistive sensors

The excellent properties of the KMZ magnetoresistive sensors, including their high sensitivity, low and stable offset, wide operating temperature and frequency ranges and ruggedness, make them highly suitable for use in a wide range of automotive, industrial and other applications. These are looked at in more detail in other chapters in this book; some general practical points about using MR sensors are briefly described below.

ANALOG APPLICATION CIRCUITRY

In many magnetoresistive sensor applications where analog signals are measured (in measuring angular position, linear position or current measurement, for example), a good application circuit should allow for sensor offset and sensitivity adjustment. Also, as the sensitivity of many magnetic field sensors has a drift with temperature, this also needs compensation. A basic circuit is shown in Fig.11.

In the first stage, the sensor signal is pre-amplified and offset is adjusted. After temperature effects are compensated, final amplification and sensitivity adjustment takes place in the last stage. This basic circuit can be extended with additional components to meet specific EMC requirements or can be modified to obtain customized output characteristics (e.g. a different output voltage range or a current output signal).

Philips magnetoresistive sensors have a linear sensitivity drift with temperature and so a temperature sensor with

linear characteristics is required for compensation. Philips KTY series are well suited for this purpose, as their positive Temperature Coefficient (TC) matches well with the negative TC of the MR sensor. The degree of compensation can be controlled with the two resistors R7 and R8 and special op-amps, with very low offset and temperature drift, should be used to ensure compensation is constant over large temperature ranges.

Please refer to part 2 of this book for more information on the KTY temperature sensors; see also the Section "Further information for advanced users" later in this chapter for a more detailed description of temperature compensation using these sensors.

USING MAGNETORESISTIVE SENSORS WITH A COMPENSATION COIL

For general magnetic field or current measurements it is useful to apply the 'null-field' method, in which a magnetic field (generated by a current carrying coil), equal in magnitude but opposite in direction, is applied to the sensor. Using this 'feedback' method, the current through the coil is a direct measure of the unknown magnetic field amplitude and it has the advantage that the sensor is being operated at its zero point, where inaccuracies as result of tolerances, temperature drift and slight non-linearities in the sensor characteristics are insignificant. A detailed discussion of this method is covered in Chapter "Weak field measurements".

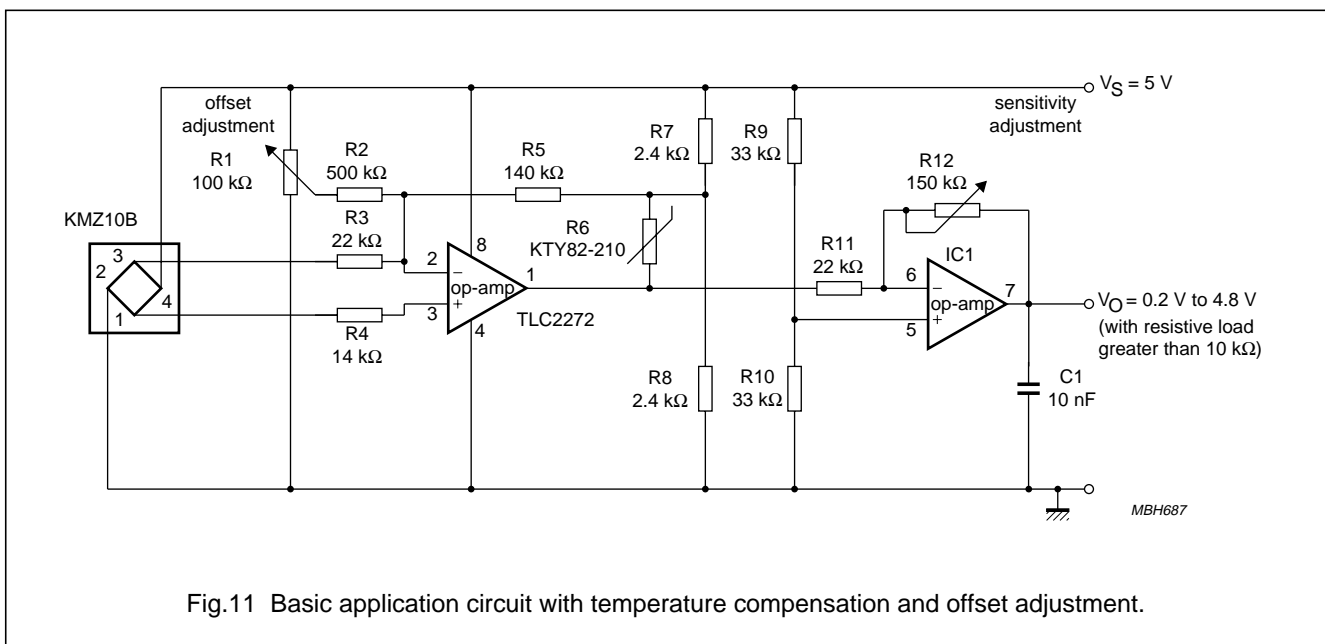

Fig.11 Basic application circuit with temperature compensation and offset adjustment.

Further information for advanced users

THE MR EFFECT

In sensors employing the MR effect, the resistance of the sensor under the influence of a magnetic field changes as it is moved through an angle α as given by:

$$R = R_0 + \Delta R_0 \cos^2 \alpha \tag{2}$$

It can be shown that

$$\sin^2 \alpha = \frac{H^2}{H_0^2} \text{ for } H \leq H_0 \tag{3}$$

and

$$\sin^2 \alpha = 1 \text{ for } H > H_0 \tag{4}$$

where H_0 can be regarded as a material constant comprising the so called demagnetizing and anisotropic fields.

Applying equations (3) and (4) to equation (2) leads to:

$$R = R_0 + \Delta R_0 \left(1 - \frac{H^2}{H_0^2} \right) \text{ for } H \leq H_0 \tag{5}$$

$$R = R_0 \text{ for } H > H_0 \tag{6}$$

which clearly shows the non-linear nature of the MR effect.

More detailed information on the derivation of the formulae for the MR effect can be found in Appendix 1.

LINEARIZATION

The magnetoresistive effect can be linearized by depositing aluminium stripes (Barber poles), on top of the permalloy strip at an angle of 45° to the strip axis (see Fig.12). As aluminium has a much higher conductivity than permalloy, the effect of the Barber poles is to rotate the current direction through 45° (the current flow assumes a 'saw-tooth' shape), effectively changing the rotation angle of the magnetization relative to the current from α to $\alpha - 45^\circ$.

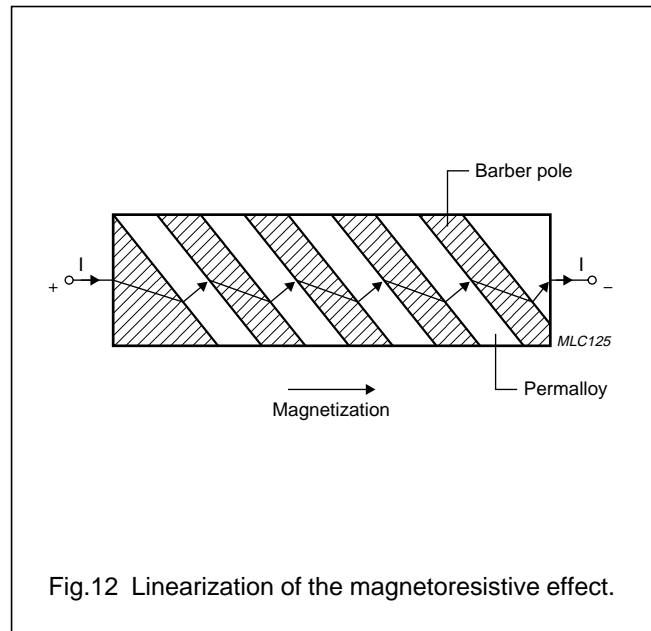

Fig.12 Linearization of the magnetoresistive effect.

A Wheatstone bridge configuration is also used for linearized applications. In one pair of diagonally opposed elements, the Barber poles are at $+45^\circ$ to the strip axis, while in another pair they are at -45° . A resistance increase in one pair of elements due to an external magnetic field is thus 'matched' by a decrease in resistance of equal magnitude in the other pair. The resulting bridge imbalance is then a linear function of the amplitude of the external magnetic field in the plane of the permalloy strips, normal to the strip axis.

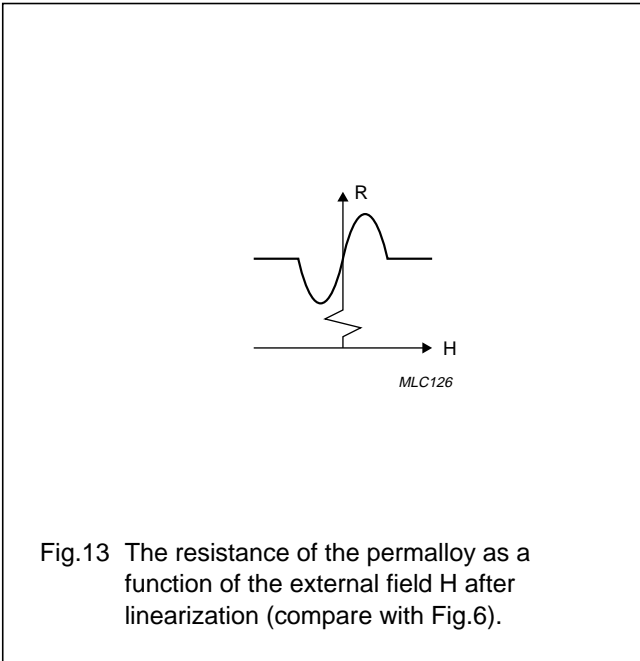

Fig.13 The resistance of the permalloy as a function of the external field H after linearization (compare with Fig.6).

For sensors using Barber poles arranged at an angle of +45° to the strip axis, the following expression for the sensor characteristic can be derived (see Appendix 1 on the MR effect):

$$R = R_0 + \frac{\Delta R_0}{2} + \Delta R_0 \left(\frac{H}{H_0} \right) \sqrt{1 - \frac{H^2}{H_0^2}} \tag{7}$$

The equation is linear where $H/H_0 = 0$, as shown in Fig.7. Likewise, for sensors using Barber poles arranged at an angle of -45°, the equation derives to:

$$R = R_0 + \frac{\Delta R_0}{2} - \Delta R_0 \left(\frac{H}{H_0} \right) \sqrt{1 - \frac{H^2}{H_0^2}} \tag{8}$$

This is the mirror image of the characteristic in Fig.7. Hence using a Wheatstone bridge configuration ensures the any bridge imbalance is a linear function of the amplitude of the external magnetic field.

FLIPPING

As described in the body of the chapter, Fig.7 shows that flipping is not instantaneous and it also illustrates the hysteresis effect exhibited by the sensor. This figure and Fig.14 also shows that the sensitivity of the sensor falls with increasing 'H_x'. Again, this is to be expected since the moment imposed on the magnetization by 'H_x' directly opposes that imposed by 'H_y', thereby reducing the degree of bridge imbalance and hence the output signal for a given value of 'H_y'.

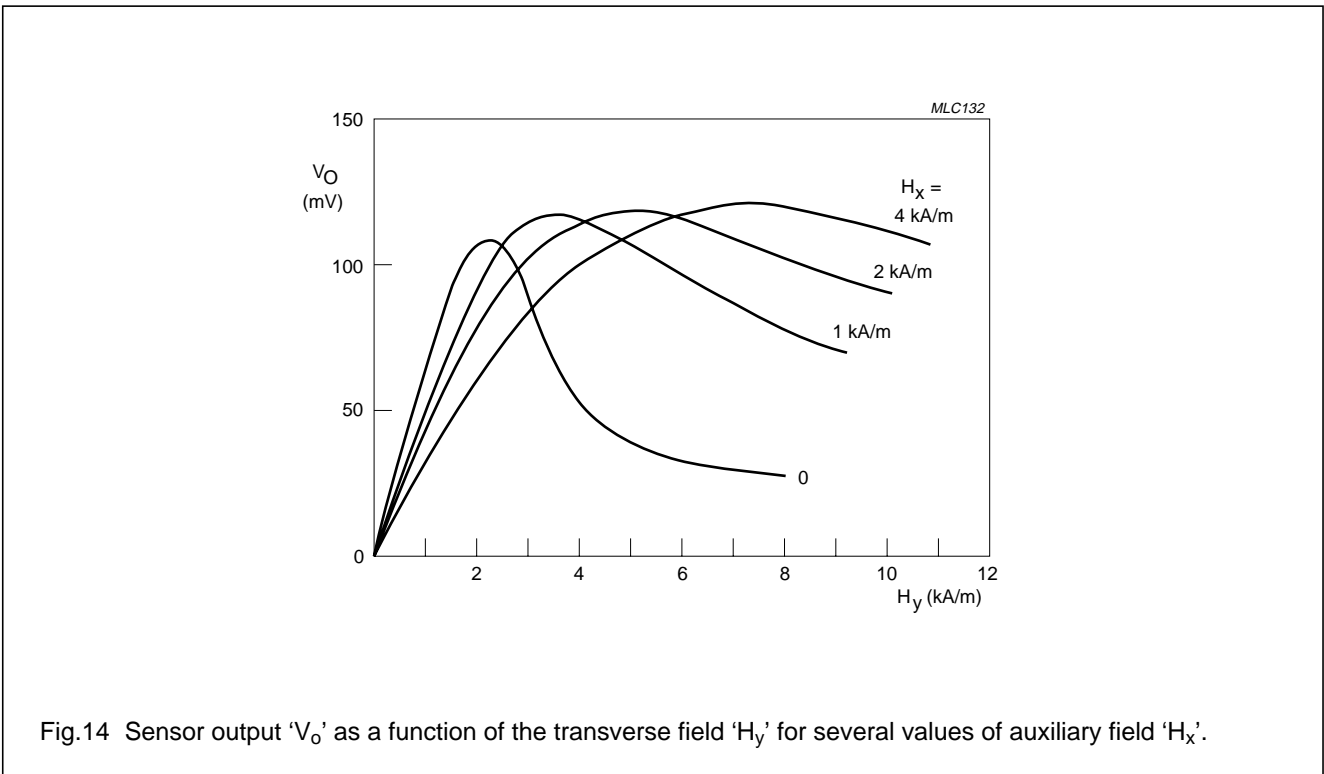

Fig.14 Sensor output 'V_O' as a function of the transverse field 'H_y' for several values of auxiliary field 'H_x'.

Magnetic field sensors

General

The following general recommendations for operating the KMZ10 can be applied:

- To ensure stable operation, avoid operating the sensor in an environment where it is likely to be subjected to negative external fields ('-H_x'). Preferably, apply a positive auxiliary field ('H_x') of sufficient magnitude to prevent any likelihood of flipping within the intended operating range (i.e. the range of 'H_y').
- Before using the sensor for the first time, apply a positive auxiliary field of at least 3 kA/m; this will effectively erase the sensor's magnetic 'history' and will ensure that no residual hysteresis remains (refer to Fig.6).
- Use the minimum auxiliary field that will ensure stable operation, because the larger the auxiliary field, the lower the sensitivity, but the actual value will depend on the value of H_d. For the KMZ10B sensor, a minimum auxiliary field of approximately 1 kA/m is recommended; to guarantee stable operation for all values of H_d, the sensor should be operated in an auxiliary field of 3 kA/m.

These recommendations (particularly the first one) define a kind of Safe Operating Area (SOAR) for the sensors. This is illustrated in Fig.15, which is an example (for the KMZ10B sensor) of the SOAR graphs to be found in our data sheets.

The greater the auxiliary field, the greater the disturbing field that can be tolerated before flipping occurs. For auxiliary fields above 3 kA/m, the SOAR graph shows that the sensor is completely stable, regardless of the magnitude of the disturbing field. It can also be seen from this graph that the SOAR can be extended for low values of 'H_y'. In Fig.15, (for the KMZ10B sensor), the extension for H_y < 1 kA/m is shown.

TEMPERATURE COMPENSATION

With magnetoresistive sensors, temperature drift is negative. Two circuits manufactured in SMD-technology which include temperature compensation are briefly described below.

The first circuit is the basic application circuit already given (see Fig.11). It provides average (sensor-to-sensor) compensation of sensitivity drift with temperature using the KTY82-210 silicon temperature sensor. It also includes offset adjustment (via R1); gain adjustment is performed with a second op-amp stage. The temperature sensor is part of the amplifier's feedback loop and thus increases the amplification with increasing temperature.

The temperature dependant amplification A and the temperature coefficient TC_A of the first op-amp stage are approximately:

$$A = \frac{R_5}{R_3} \left(1 + \frac{2R_T}{R_7} \right) \text{ for } R_8 = R_7$$

$$TC_A = \frac{TC_{KTY}}{R_7} \text{ for } R_8 = R_7$$

$$1 + \frac{2R_T}{R_7}$$

R_T is the temperature dependent resistance of the KTY82. The values are taken for a certain reference temperature. This is usually 25 °C, but in other applications a different reference temperature may be more suitable.

Figure 16 shows an example with a commonly-used instrumentation amplifier. The circuit can be divided into two stages: a differential amplifier stage that produces a symmetrical output signal derived from the magnetoresistive sensor, and an output stage that also provides a reference to ground for the amplification stage.

To compensate for the negative sensor drift, as with the above circuit the amplification is again given an equal but positive temperature coefficient, by means of a KTY81-110 silicon temperature sensor in the feedback loop of the differential amplifier.

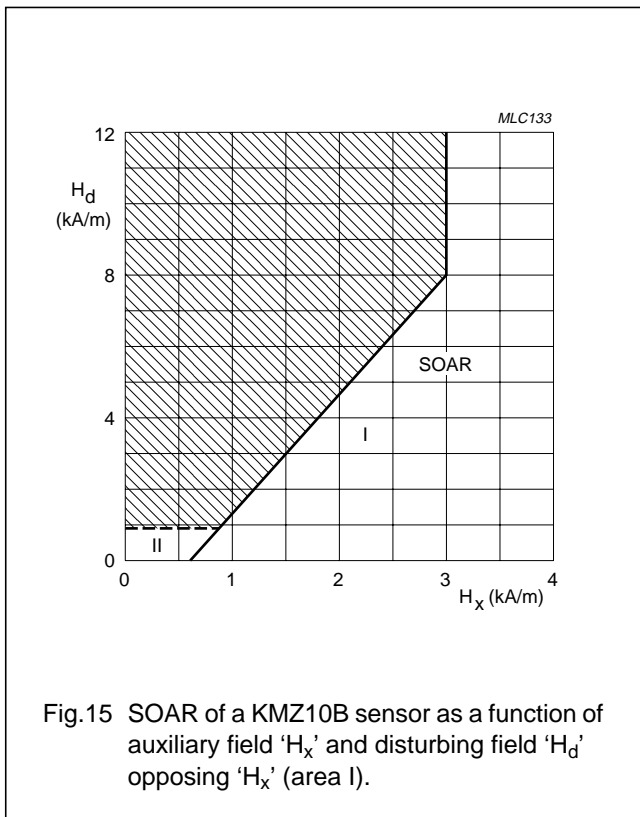

Fig.15 SOAR of a KMZ10B sensor as a function of auxiliary field 'H_x' and disturbing field 'H_d' opposing 'H_x' (area I).

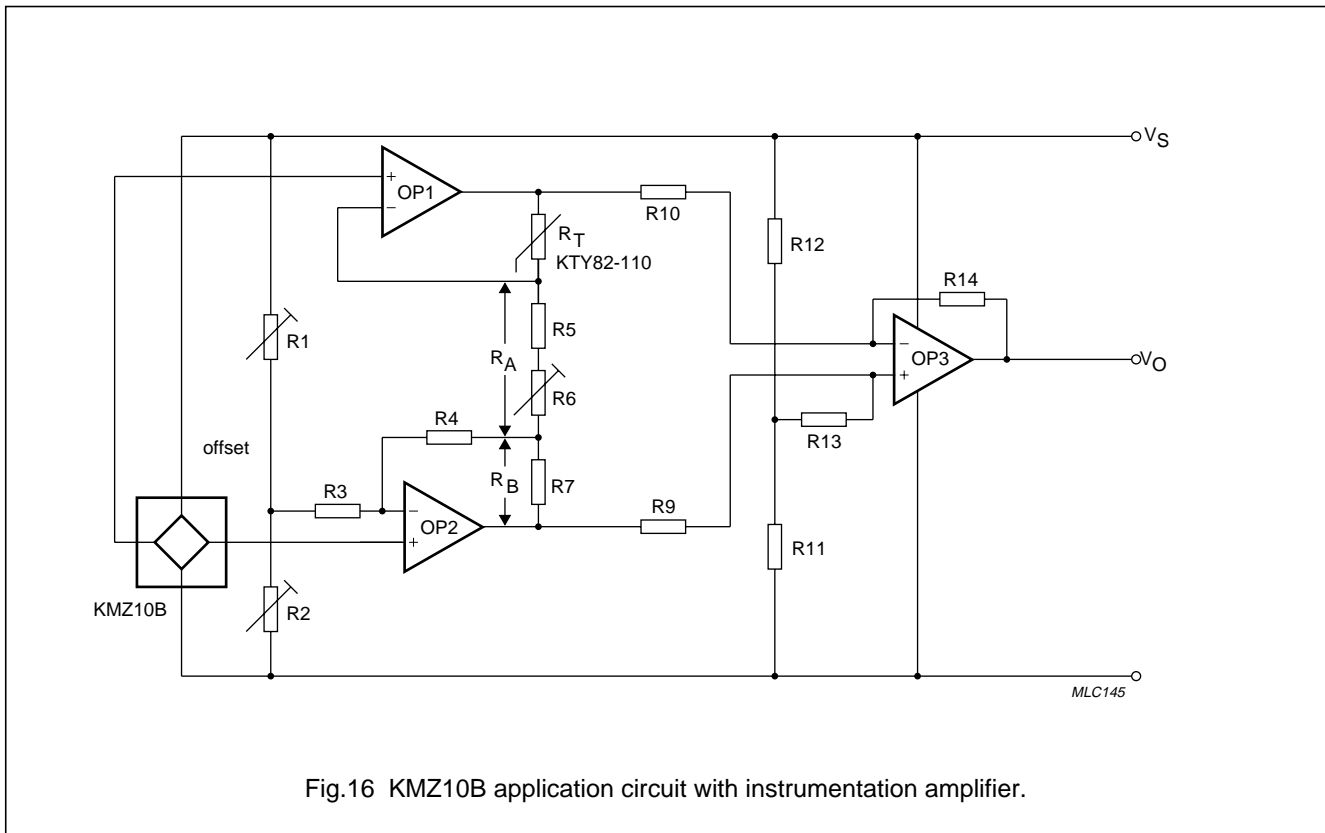

Fig.16 KMZ10B application circuit with instrumentation amplifier.

The amplification of the input stage ('OP1' and 'OP2') is given by:

$$A1 = 1 + \frac{R_T + R_B}{R_A} \tag{9}$$

where R_T is the temperature dependent resistance of the KTY82 sensor and R_B is the bridge resistance of the magnetoresistive sensor.

The amplification of the complete amplifier can be calculated by:

$$A = A1 \times \frac{R_{14}}{R_{10}} \tag{10}$$

The positive temperature coefficient (TC) of the amplification is:

$$TC_A = \frac{R_T \times TC_{KTY}}{R_A + R_B + R_T} \tag{11}$$

For the given negative 'TC' of the magnetoresistive sensor and the required amplification of the input stage 'A1', the resistance ' R_A ' and ' R_B ' can be calculated by:

$$R_B = R_T \times \left(\frac{TC_{KTY}}{TC_A} \times \left(1 - \frac{1}{A1} \right) - 1 \right) \tag{12}$$

$$R_A = \frac{R_T + R_B}{A1 - 1} \tag{13}$$

where TC_{KTY} is the temperature coefficient of the KTY sensor and TC_A is the temperature coefficient of the amplifier. This circuit also provides for adjustment of gain and offset voltage of the magnetic-field sensor.

WEAK FIELD MEASUREMENTS**Contents:**

- Principles of weak field sensing
- Philips sensors for weak field measurement
- Application examples
- Test modules.

Principles of weak field sensing

Measurement of weak magnetic fields such as the earth's geomagnetic field (which has a typical strength of between approximately 30 A/m and 50 A/m), or fields resulting from very small currents, requires a sensor with very high sensitivity. With their inherent high sensitivity, magnetoresistive sensors are extremely well suited to sensing very small fields.

Philips' magnetoresistive sensors are by nature bi-stable (refer to Appendix 2). 'Standard' techniques used to stabilize such sensors, including the application of a strong field in the x-direction (H_x) from a permanent stabilization magnet, are unsuitable as they reduce the sensor's sensitivity to fields in the measurement, or y-direction (H_y). (Refer to Appendix 2, Fig. A2.2).

To avoid this loss in sensitivity, magnetoresistive sensors can instead be stabilized by applying brief, strong non-permanent field pulses of very short duration (a few μ s). This magnetic field, which can be easily generated by simply winding a coil around the sensor, has the same stabilizing effect as a permanent magnet, but as it is only present for a very short duration, after the pulse there is no loss of sensitivity. Modern magnetoresistive sensors specifically designed for weak field applications incorporate this coil on the silicon.

However, when measuring weak fields, second order effects such as sensor offset and temperature effects can greatly reduce both the sensitivity and accuracy of MR sensors. Compensation techniques are required to suppress these effects.

OFFSET COMPENSATION BY 'FLIPPING'

Despite electrical trimming, MR sensors may have a maximum offset voltage of ± 1.5 mV/V. In addition to this static offset, an offset drift due to temperature variations of about $6 (\mu\text{V/V})\text{K}^{-1}$ can be expected and assuming an ambient temperature up to 100 °C, the resulting offset can be of the order of 2 mV/V.

Taking these factors into account, with no external field a sensor with a typical sensitivity of $15 \text{ mV/V (kA/m)}^{-1}$ can have an offset equivalent to a field of 130 A/m, which is itself about four times the strength of a typical weak field such as the earth's geomagnetic field. Clearly, measures to compensate for the sensor offset value have to be implemented in weak field applications.

A technique called 'flipping' (patented by Philips) can be used to control the sensor. Comparable to the 'chopping' technique used in the amplification of small electrical signals, it not only stabilizes the sensor but also eliminates the described offset effects.

When the bi-stable sensor is placed in a controlled, reversible external magnetic field, the polarity of the premagnetization (M_x) of the sensor strips can be switched or flipped between the two output characteristics (see Fig.17).

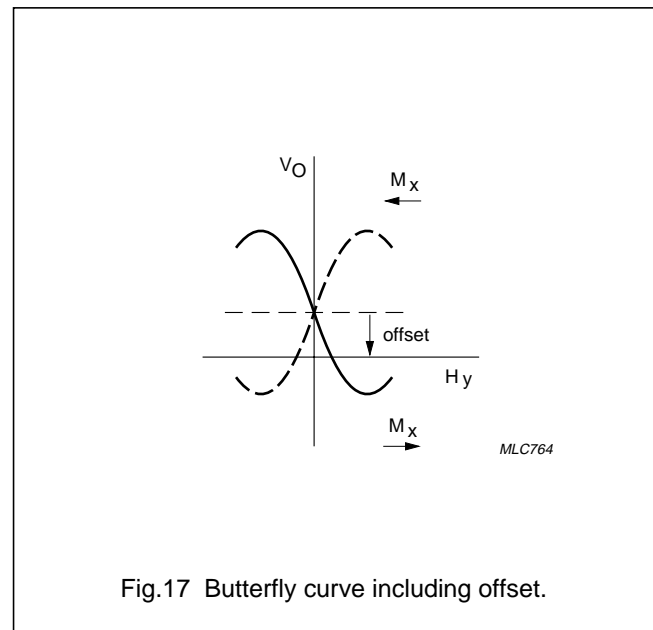
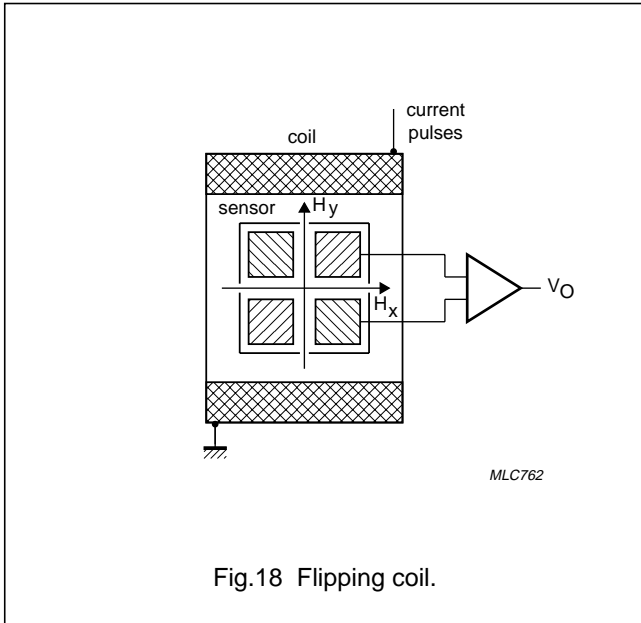

Fig.17 Butterfly curve including offset.

This reversible external magnetic field can be easily achieved with a coil wound around the sensor, consisting of current carrying wires, as described above. Depending on the direction of current pulses through this coil, positive and negative flipping fields in the x-direction ($+H_x$ and $-H_x$) are generated (see Fig.18). Although in principle the flipping frequency need not be an exact figure, design hints are given in the Section "Typical drive circuit".



Flipping causes a change in the polarity of the sensor output signal and this can be used to separate the offset signal from the measured signal. Essentially, the unknown field in the 'normal' positive direction (plus the offset) is measured in one half of the cycle, while the unknown field in the 'inverted' negative direction (plus the offset) is measured in the second half. This results in two different outputs symmetrically positioned around the offset value. After high pass filtering and rectification a single, continuous value free of offset is output, smoothed by low pass filtering. See Figs 19 and 20.

Offset compensation using flipping requires additional external circuitry to recover the measured signal.

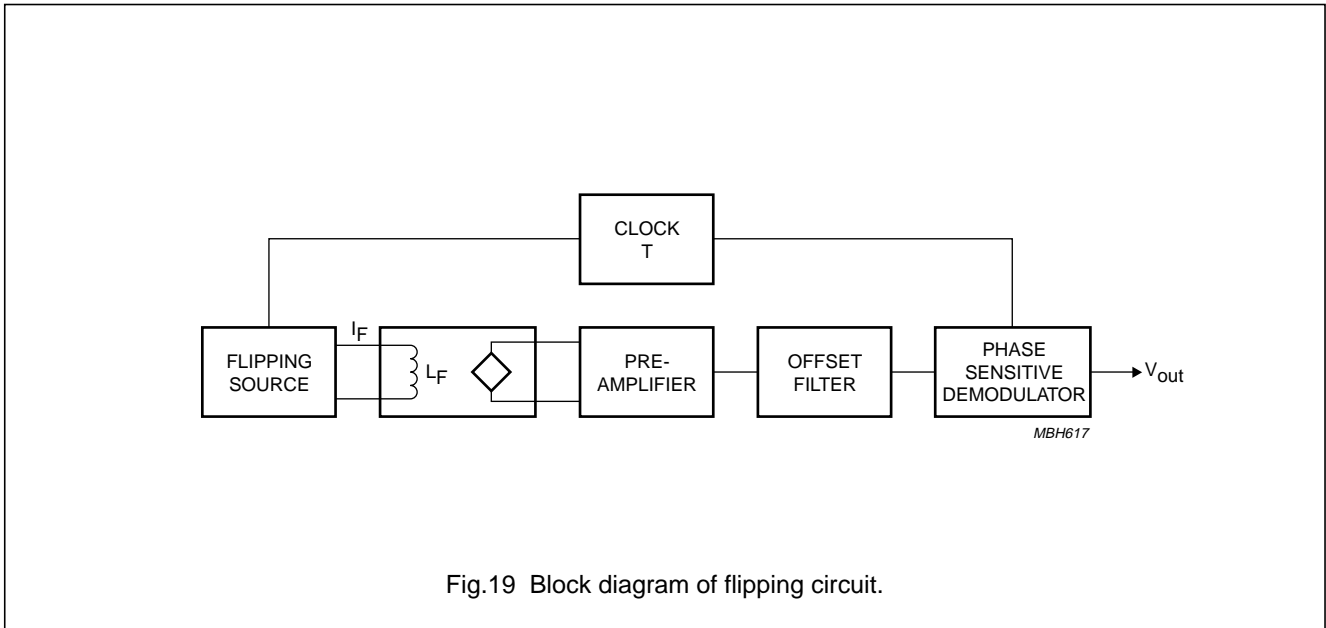

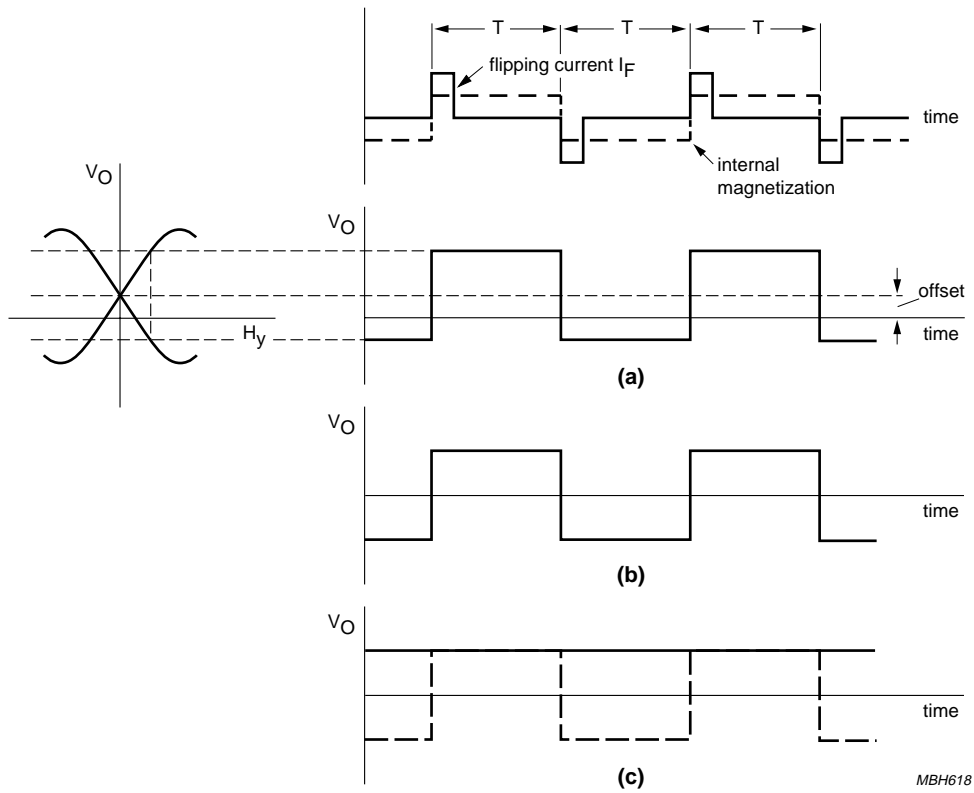

Fig.20 Timing diagram for flipping circuit (a) output voltage; (b) filtered output voltage; (c) output voltage filtered and demodulated.

SENSOR TEMPERATURE DRIFT

The sensitivity of MR sensors is also temperature dependent, with sensitivity decreasing as temperature increases (Fig.21). The effect on sensor output is certainly

not negligible, as it can produce a difference of a factor of three within a $-25\text{ }^{\circ}\text{C}$ to $+125\text{ }^{\circ}\text{C}$ temperature range, for fields up to 0.5 kA/m . This effect is not compensated for by the flipping action described in the last section.

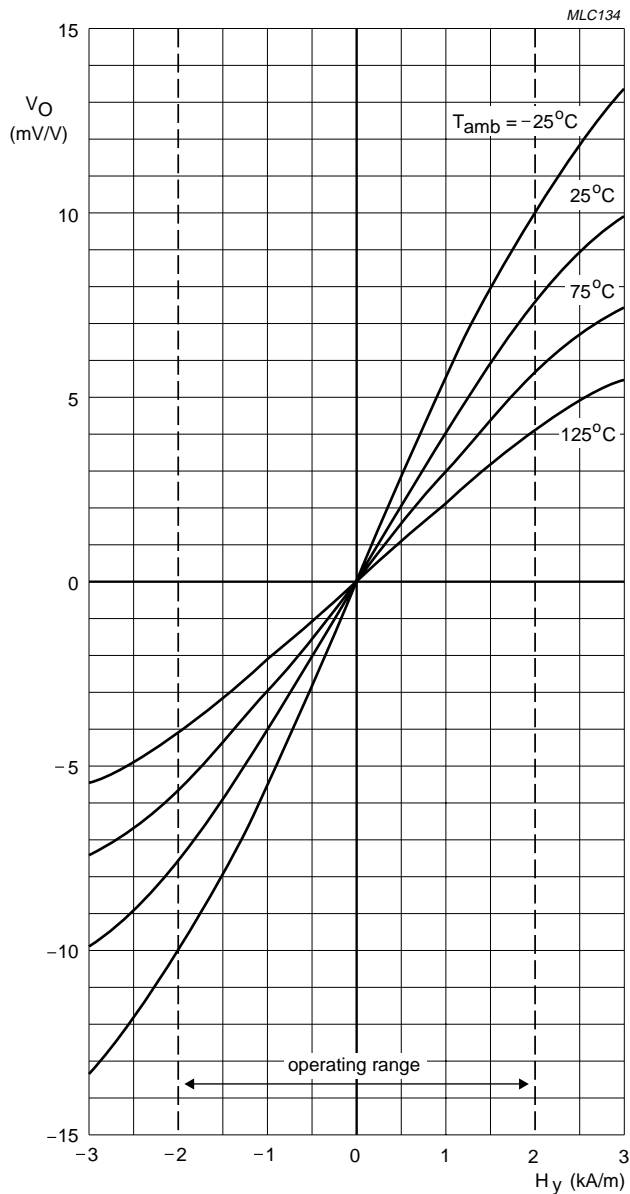

Fig.21 Output voltage ' V_o ' as a fraction of the supply voltage for a KMZ10B sensor, as a function of transverse field ' H_y ', at several temperatures.

Magnetic field sensors

General

The simplest form of temperature compensation is to use a current source to supply to the sensor instead of a voltage source. In this case, the resulting reduction in sensitivity due to temperature is partially compensated by a corresponding increase in bridge resistance.

Thus a current source not only improves the stability of the output voltage 'V_o', and reduces the variation in sensitivity to a factor of approximately 1.5 (compared to a factor of three using the voltage source). However, this method requires a higher supply voltage, due to the voltage drop of the current source.

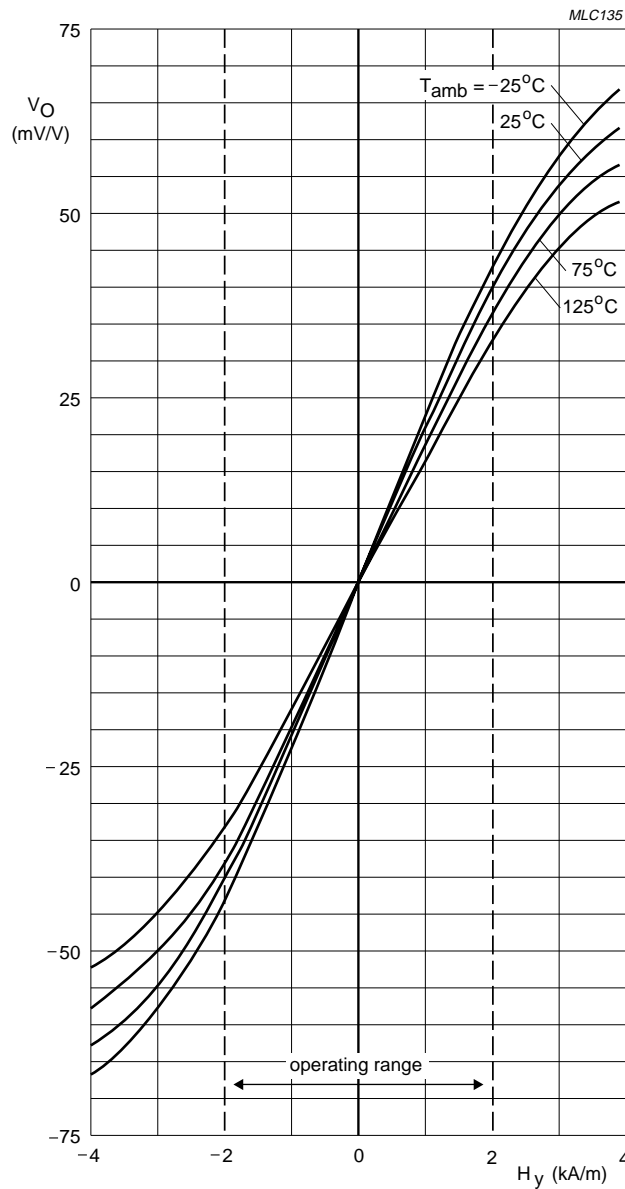

Fig.22 Output voltage 'V_o' of a KMZ10B sensor as a function of transverse field 'H_y' using a current source, for several temperatures.

Magnetic field sensors

General

The optimal method of compensating for temperature dependent sensitivity differences in MR measurements of weak fields uses electro-magnetic feedback. As can be seen from the sensor characteristics in Figs 21 and 22, sensor output is completely independent of temperature changes at the point where no external field is applied (the null-point). By using an electro-magnetic feedback set-up, it is possible to ensure the sensor is always operated at this point.

To achieve this, a second compensation coil is wrapped around the sensor perpendicular to the flipping coil, so that the magnetic field produced by this coil is in the same plane as the field being measured.

Should the measured magnetic field vary, the sensor's output voltage will change, but the change will be different at different ambient temperatures. This voltage change is converted into a current by an integral controller and supplied to the compensation coil, which then itself produces a magnetic field proportional to the output voltage change caused by the change in measured field.

The magnetic field produced by the compensation coil is in the opposite direction to the measured field, so when it is added to the measured field, it compensates exactly for the change in the output signal, regardless of its actual, temperature-dependent value. This principle is called current compensation and because the sensor is always used at its 'zero' point, compensation current is independent of the actual sensitivity of the sensor or sensitivity drift with temperature.

Information on the measured magnetic signal is effectively given by the current fed to the compensating coil. If the field factor of the compensation coil is known, this simplifies calculation of the compensating field from the compensating current and therefore the calculation of the measured magnetic field. If this field factor is not precisely known, then the resistor performing the current/voltage conversion must be trimmed. Figure 24 shows a block diagram of a compensated sensor set-up including the flipping circuit.

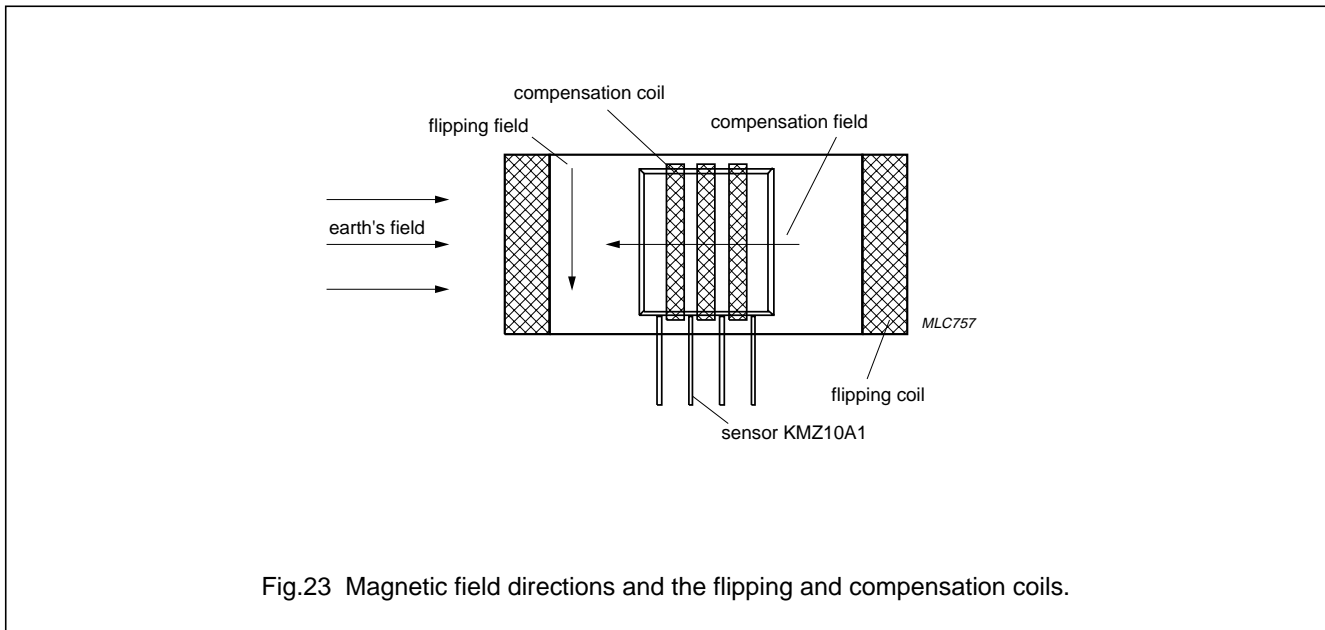

Fig.23 Magnetic field directions and the flipping and compensation coils.

Magnetic field sensors

General

The influence of other disturbing fields can also be eliminated provided they are well known, by adding a second current source to the compensating coil. Such fields might be those arising from the set-up housing, ferromagnetic components placed close to the sensor or magnetic fields from electrical motors.

The brief summary in Table 3 compares the types of compensation and their effects, so they can be assessed for their suitability in a given application. Because these options encompass a range of costs, the individual requirements of an application should be carefully analysed in terms of the performance gains versus relative costs.

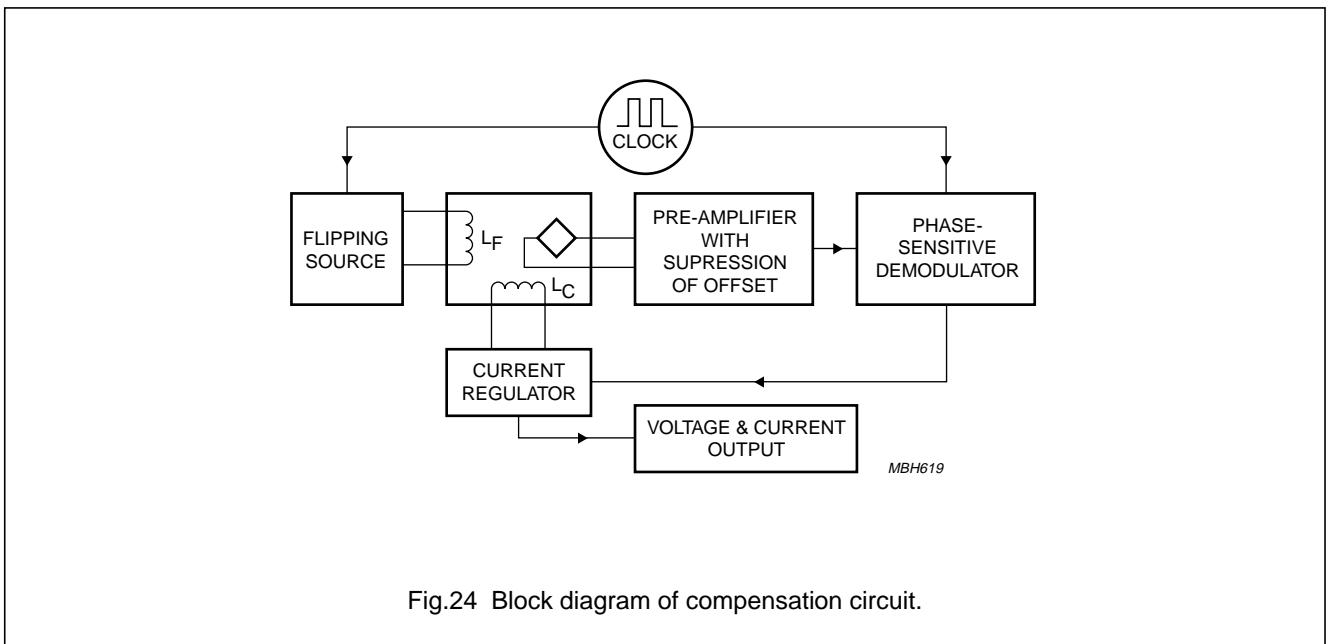

Fig.24 Block diagram of compensation circuit.

Table 3 Summary of compensation techniques

TECHNIQUE	EFFECT
Setting	avoids reduction in sensitivity due to constant stabilization field
Flipping	avoids reduction in sensitivity due to constant stabilization field, as well as compensating for sensor offset and offset drift due to temperature
Current supply	reduction of sensitivity drift with temperature by a factor of two
Electro-magnetic feedback	accurate compensation of sensitivity drift with temperature

Philips sensors for weak field measurement

Philips Semiconductors has at present four different sensors suitable for weak field applications, with the primary device being the KMZ51, an extremely sensitive sensor with integrated compensation and set/reset coils. (see Fig.25)

This sensor is ideal for many weak field detection applications such as compasses, navigation, current

measurement, earth magnetic field compensation, traffic detection and so on. The integrated set/reset coils provide for both the flipping required in weak field sensors and also allow setting/resetting the orientation of the sensitivity after proximity to large disturbing magnetic fields. Philips also has the KMZ10A and KMZ10A1, similar sensors which do not have integrated coils and therefore require external coils. Table 4 provides a summary of the main single sensors in Philips' portfolio for weak field measurement.

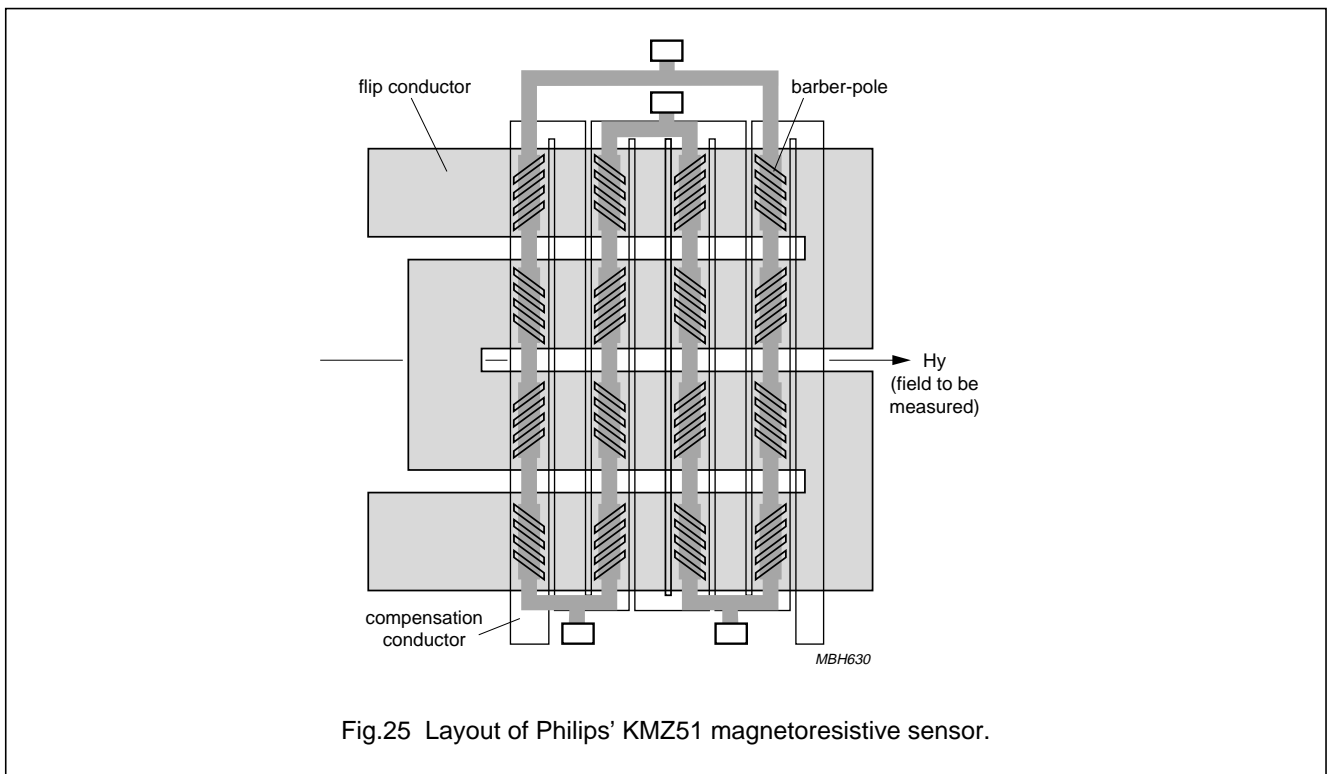

Table 4 Properties of Philips Semiconductors single sensors for a weak field applications

	KMZ10A	KMZ10A1	KMZ50	KMZ51	UNIT
Package	SOT195	SOT195	SO8	SO8	-
Supply voltage	5	5	5	5	V
Sensitivity	16 ⁽¹⁾	22	16	16	(mV/V)/ (kA/m)
Offset voltage	±1.5	±1.5	±1	±1	mV/V
Offset voltage temperature drift	±6	±6	±3	±3	µV/V/K
Applicable field range (y-direction)	±0.5	±0.5	±0.2	±0.2	kA/m
Set/reset coil on-board	no	no	yes	yes	-
Compensation coil on-board	no	no	no	yes	-

Note

1. $H_x = 0.5$ kA/m.

Typical drive circuit

The principles of an application circuit required to achieve the performance mentioned, using the KMZ51, are described below (based on the simplified circuit in Fig.26). The fully compensated circuit is described; various elements which can be omitted are also indicated, if the application dictates that a given functional block is not needed. All figures quoted and the oscillograph (see Fig.27) were obtained using the circuit shown in Fig.35.

A. FLIPPING CIRCUIT WITH COMPENSATION

Although the circuit described here uses a KMZ51 sensor with its integrated coils, circuits for the KMZ10A or the KMZ10A1 would essentially be similar. However, in these cases the drive circuitry for the flipping and compensation coils would probably have to be adapted to provide a different drive capability, as the coil field factor can vary for these sensors due to the differing current density of external wire-wound coils. (The field factor for the KMZ51 is 22 A/m.mA^{-1}).

This depends on the number of windings and the naturally larger chip-coil distance for external coils.

The energy that needs to be expended to generate the same physical effect using discrete coils is much higher than with the KMZ51 integrated solution, to the point where applications with a 5 V supply may become unfeasible. Also, there are competitive products that also have integrated coils, but which have a worse field factor than that produced by the patented design of the KMZ51. These may require expensive DC-DC converters to drive the necessary current through the coils.

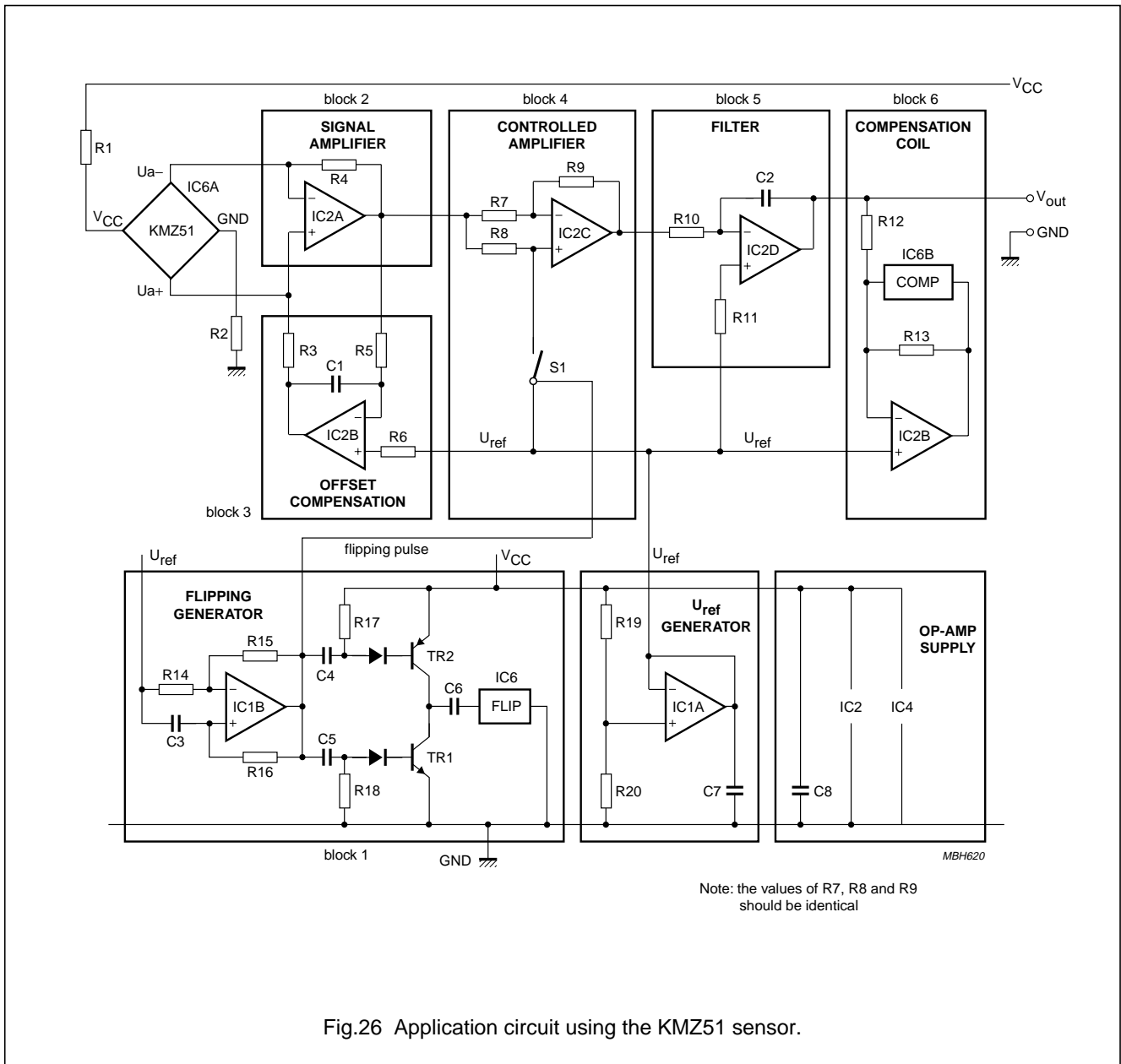

Fig.26 Application circuit using the KMZ51 sensor.

The 'flipper' circuit (Block 1) generates the flipping current, with a flipping frequency determined by R16 and C3, about 1 kHz in this case. As previously stated, the frequency is not critical and can be selected to minimize the need for post filtering and/or to provide the required response time.

The flipping frequency drives the synchronous rectifier as well as the flipping coil. As the signal passes from high to low, C4/R17 together produce a pulse that switches TR2 on. This charges C6 and a short positive pulse is passed to the flipping coil. For a low-to-high signal transition,

C5/R18 forces TR1 to conduct, making C6 discharge and providing a negative pulse through to coil. An oscillograph of the current through the flipping coil is shown in Fig.27c, with a duration of about 10 μ s and maximum current amplitude of around 0.7 A. The other diagrams show the responses of offset compensation (Fig.27b), and measuring magnetic pulses (Fig.27a).

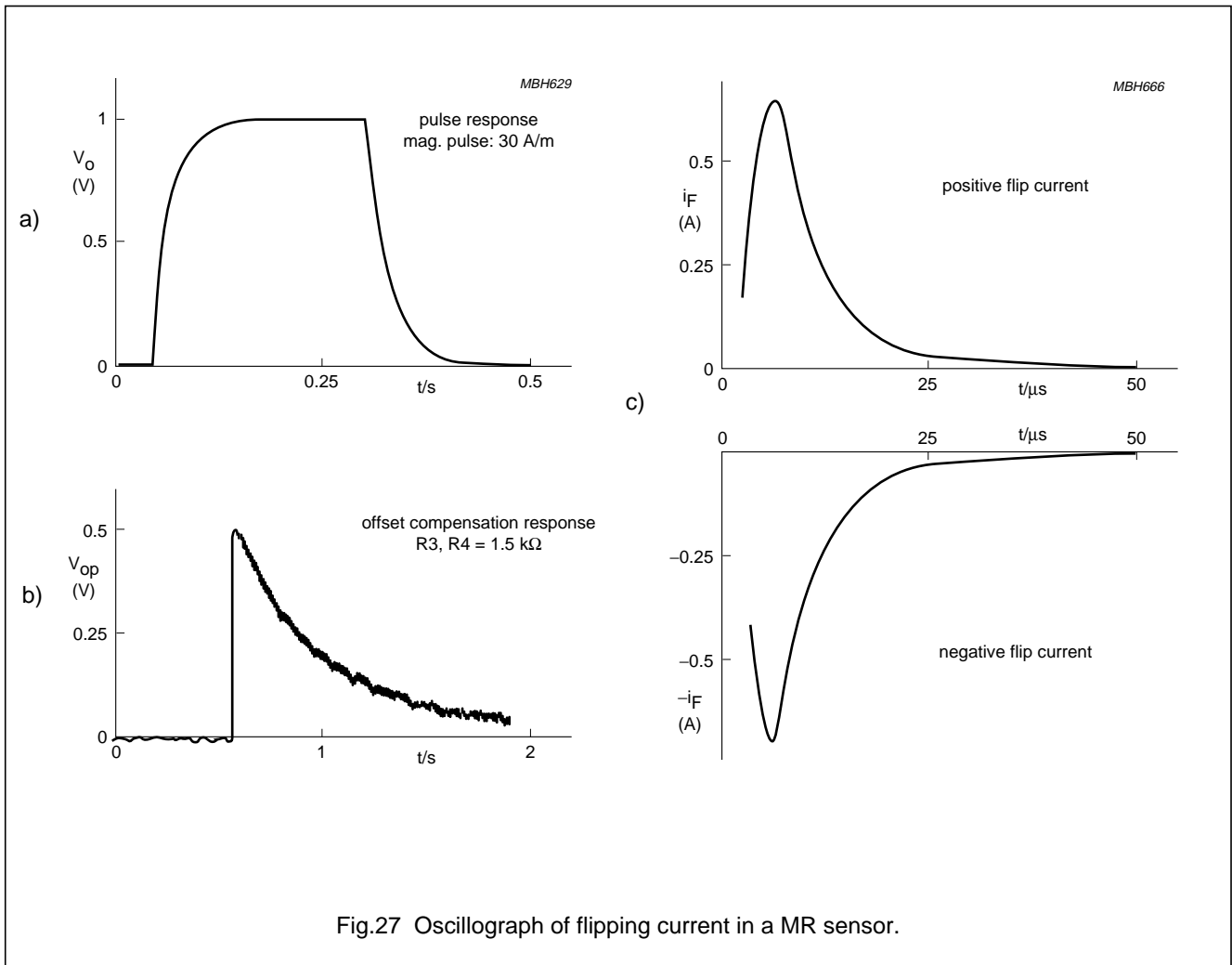

Fig.27 Oscillograph of flipping current in a MR sensor.

This circuit actually produces the necessary supply to drive two flipping coils, which may be needed in some applications such as an electronic compass (see Section "Application examples"). Another separate clock or clock generated by a μP in the system could also be used to drive TR1 and TR2.

The two resistors, R1 and R2, reduce the supply voltage of the set-up down to the level required for the sensor bridge, in this case reducing $V_{CC} = 10$ V down to about 5 V. The flipped output signal of the sensor bridge is amplified by the pre-amplification circuit (Block 2) by a factor of 100, providing a signal up to about 300 mV_{PP} (given a field of about 15 A/m in the sensor plane). Of course, this voltage would only be visible in un-compensated mode; when the circuit is being used in compensated mode, this voltage will be approximately 0 mV_{PP}.

Referring to the block diagram, Fig.26, the integrator around IC2B in Block 3 provides the filtering to remove the offset. In fact, in this set-up it is performed with a low pass filter rather than high pass filtering. The low-pass filter extracts the offset and uses it as negative feedback at IC2A. It does not use the measured signal which, because of the flipping, is now a signal modulated at the flipping frequency. This has two main advantages:

- The op-amp in Block 2 is only amplifying the wanted signal, allowing the gain to be higher with no overload (or clipping) due to DC components.
- The offset of the op-amp in Block 2 will also be compensated, eliminating the need for special low offset amplifiers, reducing overall system costs.

The design of this filter affects system performance significantly. In this example, the flipping frequency is 1 kHz with a filter roll off of 4 Hz.

Block 4 (rectification) performs synchronous rectification of the flipped signal, to recover measured field information. If $R7 = R8 = R9$ this block performs alternate +1 and -1 amplification, depending whether the sensor is operating with a normal or inverted characteristic. When the flipping signal is LOW, switch S1 is closed and the op-amp acts as an inverting amplifier (-1 amplification); if the flipping signal is HIGH, then S1 is open and the amplification is +1 and no modifications are made to the input signal. With this rectification, the offset-compensated measured signal is recovered from the original sensor signal.

Block 5 smoothes the rectified signal so that a single continuous output signal is generated. As long as a compensation coil is used, it is recommended that this filter is also used, to ensure stable operation. If compensation is not used, then it is possible to use less expensive components. This block, as well as the rectifier Block 4 can even be omitted entirely if, for example, the output signal is then passed to a microcontroller which can easily perform the rectification and smoothing, especially if it is also being used to generate the flipping frequency.

The components in Block 6 drive the compensation coil and ensure that V_{out} is proportional to the compensation current. If the application does not need the highest accuracy, reduced circuit complexity can be used.

B. FLIPPING CIRCUIT WITH NO OFFSET COMPENSATION

In this case, Block 3 should be removed.

C. CIRCUIT WITH NO FLIPPING COMPENSATION

If a stabilization magnet or periodic re-setting is used instead of flipping, then Block 3 (flipping filter), Block 4 (rectifier) and Block 5 (smoothing) can be omitted. The flipping generation circuitry can also be simplified (by leaving out C5, R18, and TR1) or omitted if a stabilization magnet is used.

D. GENERAL REMARKS

The circuitry described above operates with inexpensive op-amps such as the LM324 and LM532, keeping costs low. However, this represents just one possible system solution and, depending on the required functions, further reductions in cost can be achieved by replacing the op-amps with transistor solutions. In designs that do not utilize some blocks in the circuit, such as offset compensation, this should certainly be considered. A very simple set-up can be used if a microprocessor is already available within the system (Fig.28).

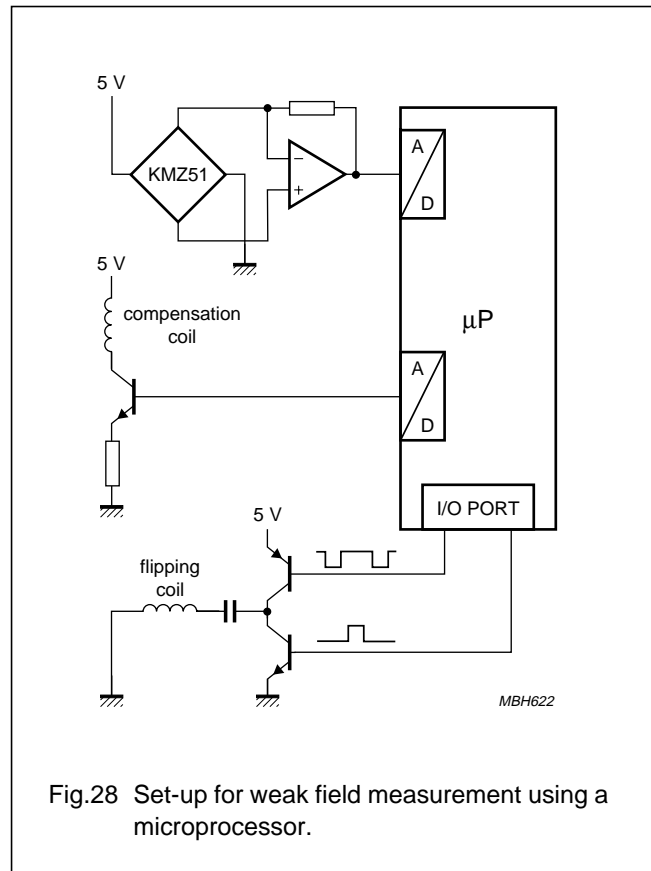

Fig.28 Set-up for weak field measurement using a microprocessor.

Application examples

In this section, we look at three weak field measurement applications:

1. Electronic compass
2. Earth geomagnetic field compensation in CRTs
3. Traffic detection.

Note: topics related to the measurement of weak currents are described in detail in Chapter "Current measurement".

ELECTRONIC COMPASS

A typical application of weak field measurement is that of the electronic compass. Here, two sensors are aligned in the same plane but at 90 degrees to one another. This provides a two dimensional compass, with the sensors measuring the x- and y-components of the measured (earth) field.

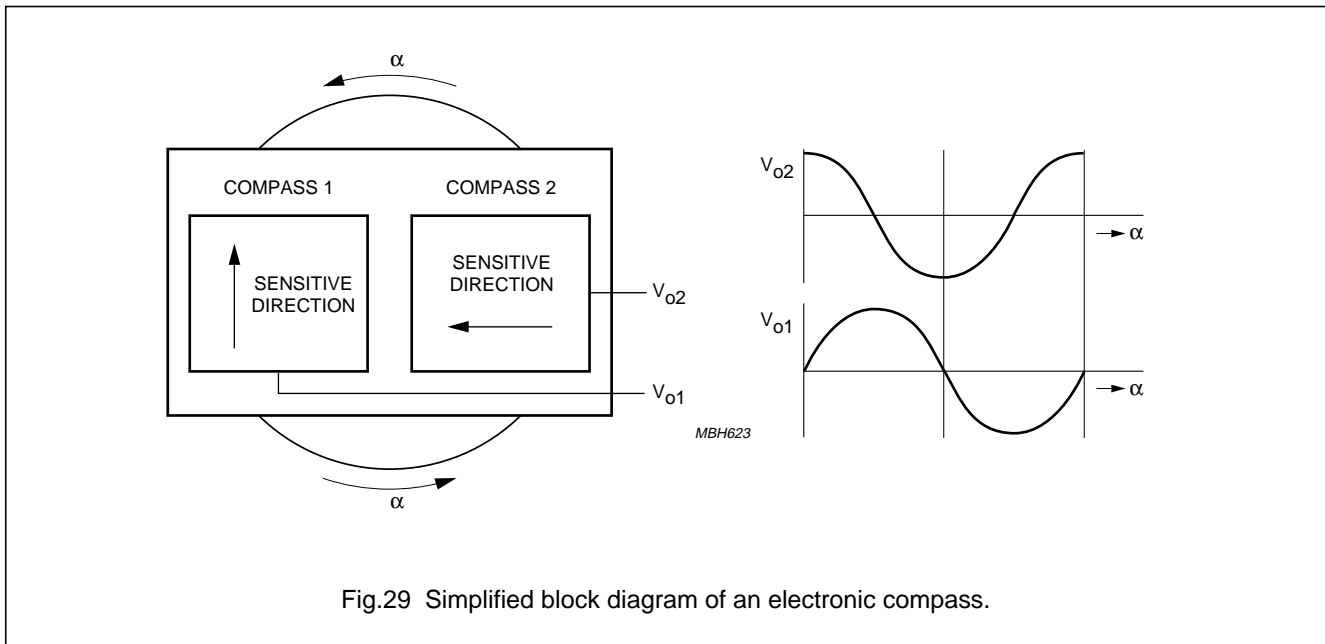

Fig.29 Simplified block diagram of an electronic compass.

Both of the sensors deliver a single sinewave when rotated in the Earth's geomagnetic field (see Fig.29). This two dimensional compass is sensitive to the angle α between the Earth's surface and the measurement plane of the sensors: a change in this angle will change the alignment between the sensitivity axis of the sensor and the Earth's field, and therefore affect sensor output. This effect, similar to that seen in conventional compasses, can be clearly observed in automotive applications, when a car is going up- or downhill. High precision systems eliminate this problem using a three dimensional compass and a gravity sensor.

Table 5 Typical disturbances in compass systems for different angles α

LOCATION	ANGLE α		
	5°	10°	15°
Zürich	9.7°	18.8°	26.9°
Hamburg	12.5°	23.8°	33.3°
Anchorage	17°	31.2°	42.1°
Singapore	1.5°	2.9°	4.3°
Tokyo	5.7°	11.2°	16.5°

Various levels of complexity can be incorporated in the drive circuit, to include the various compensation techniques described earlier in this chapter, depending on the level of accuracy required and expected environmental

influences. A basic and a high-end compass example are described below.

A. Simple 8-segment compass

The main function of a simple compass application is to purely indicate direction (N, NE, E, etc.). This basic functionality is typically found in simple navigation aids where, for example, car drivers may require only an indication of their orientation and not an accurate indication of their direction. For such simple application set-ups, the accuracy produced by the sensor electronics need only be of the order of 3°.

In such a simple compass application, the compass may be required only to display the eight major compass directions. In this case, the two output signals can be compared with each other to achieve three digital signals (Fig.31). These provide the basic N, S, E, W information while a third, inverted sensor signal determines whether the sensor signal is changing positively or negatively and this is included in the comparison, to distinguish between the eight positions on the compass. Simple comparators can be used to obtain three digital signals, which drive a display unit via a multiplexer.

Note: Figure 30 shows the principles of a typical compass sensor set-up and for maximum clarity, compensation and flipping coils are shown separately. Of course the KMZ51, which has compensation and flipping coils incorporated into the sensor housing, would be used in a real-life application.

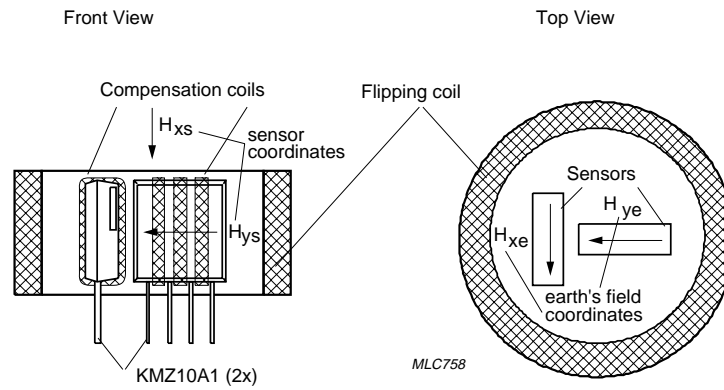

Fig.30 Compass sensor system.

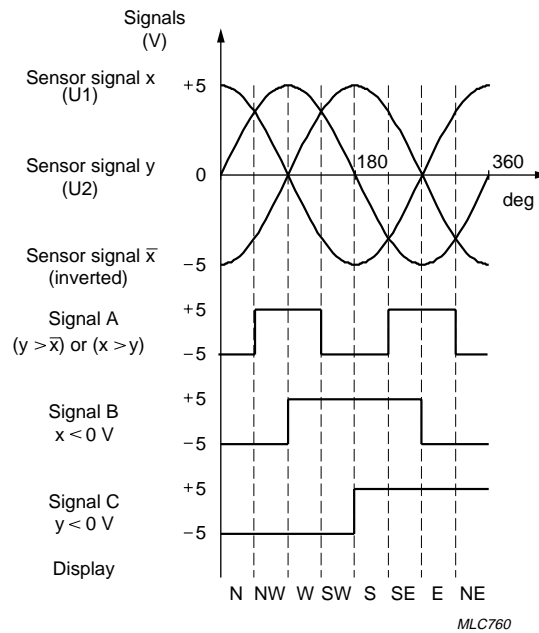

Fig.31 Evaluated signals.

B. High-end compass

Compass resolution can be increased from the basic eight by adapting the evaluation circuit and using a microcontroller to calculate the arctan function of the ratio of the two signals to determine the angle. The resolution of the compass then depends on the microcontroller and the A/D converters used. The use of a microcontroller also enables additional functionality, such as storing a reference direction or eliminating magnetic influences from encapsulation or other magnetic components.

Simple alignment using opposite directions

Electronic compasses need calibrating to eliminate the effects of these extraneous fields produced, for example, by the compass casing. The simplest method is known as Bi-directional Calibration. Requiring no external calibration devices, in this technique the output is measured twice with each measurement shifted by 180°. From this, the x- and y- components of the extraneous field can be determined and simply compensated for by applying the appropriate current to the coils, synthesizing a compensation field.

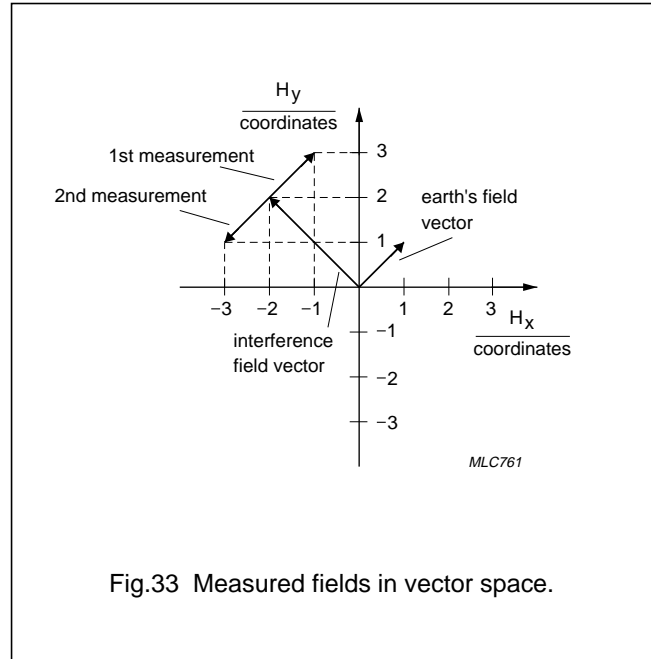

Fig.33 Measured fields in vector space.

Continuous alignment

With high-end compass applications, the microcontroller can also be used to adjust the calibration of the compass continually. This is especially useful in automotive compasses, eliminating the need for manual re-adjustment according to variable vehicle load.

Compass test units

For test purposes, Philips designed an SMD board (Figs 34 and 35) with the following parameters:

- Supply: 10 V
- Current: 25 mA (typ.)
- $V_{O(x,y)}$: 30 mV per A/m ($V_x, V_y \leftrightarrow V_{ref}$)
- Load: >10 k Ω
- $I_{O(x,y)}$: 62.5 μ A per A/m (5 mA/Gauss) ($I_x, I_y \leftrightarrow V_{ref}$)
- Noise: 0.05 A/m
- Range: 100 A/m
- Load: <70 Ω (<500 Ω at $V_{CC} = 16$ V)
- Bandwidth: \approx 10 Hz.

An SMD compass sensor test unit was rotated in an Earth field rotational unit, resulting in the test-diagram shown in Fig.36.

Note: U_{ref} is internally generated on the board, it does not need to be provided externally.

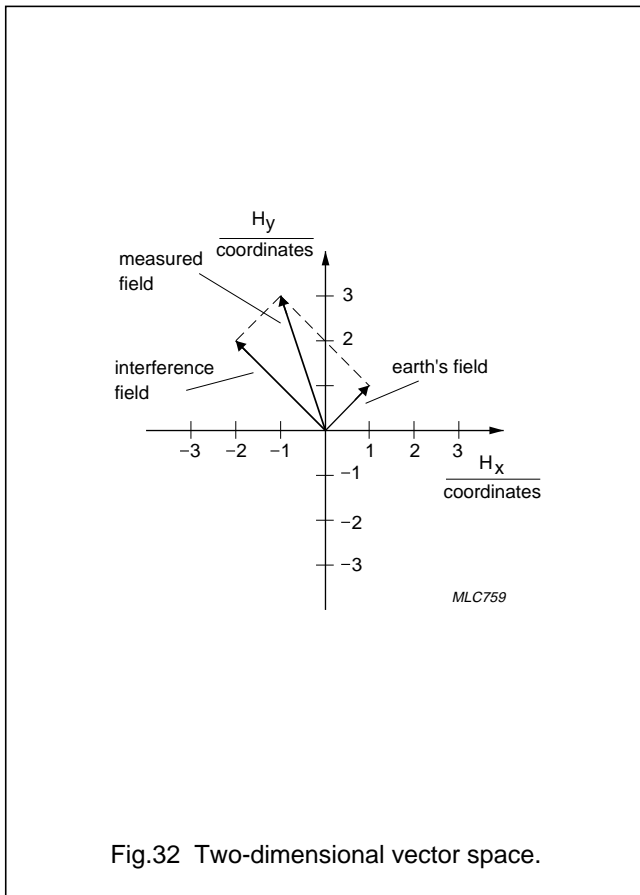

Fig.32 Two-dimensional vector space.

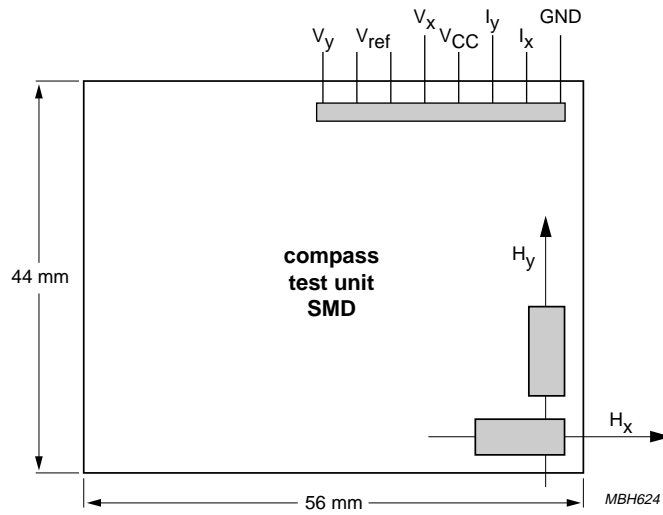

Fig.34 SMD test unit.

Magnetic field sensors

General

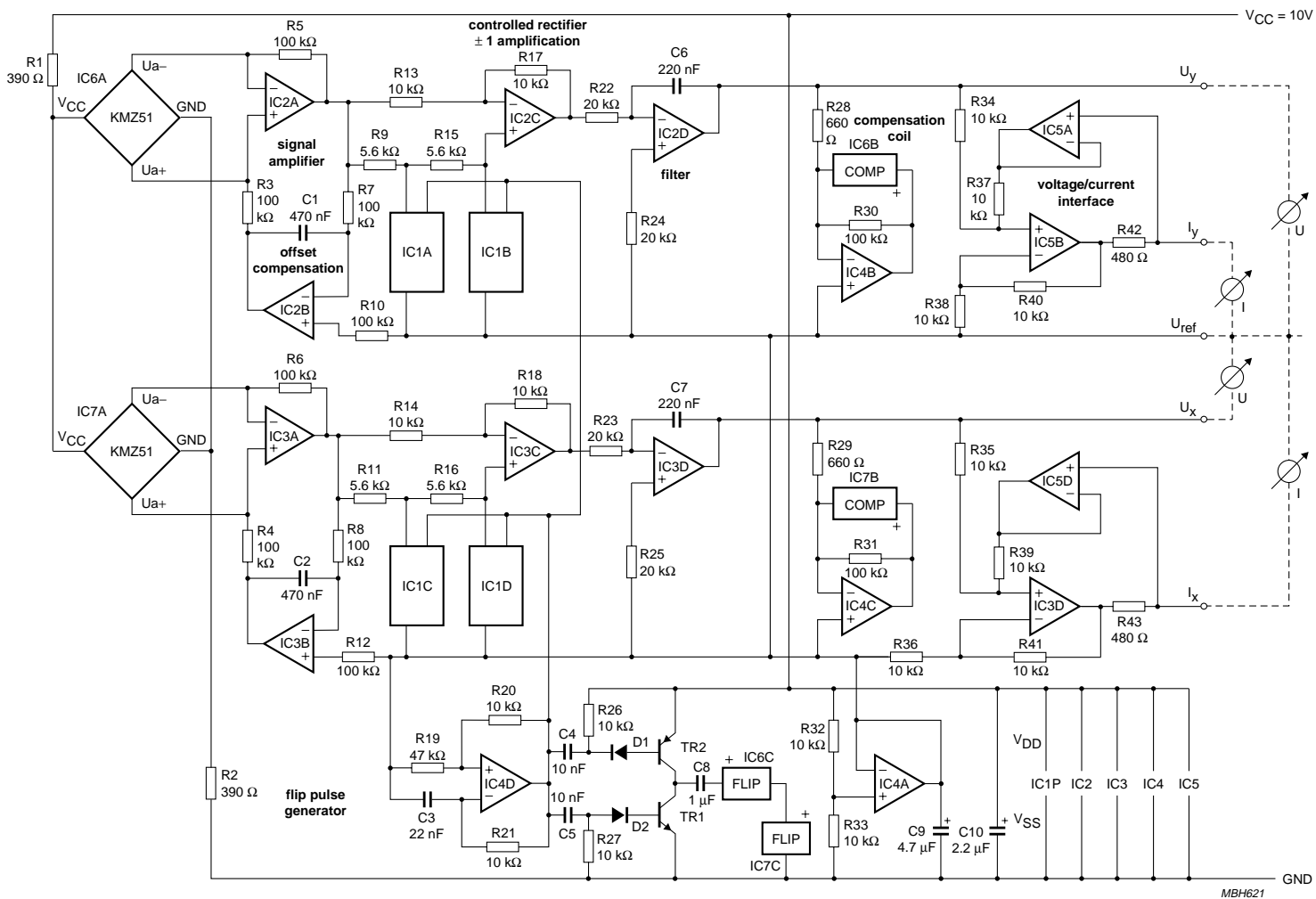

Fig.35 Circuit diagram for an electronic compass.

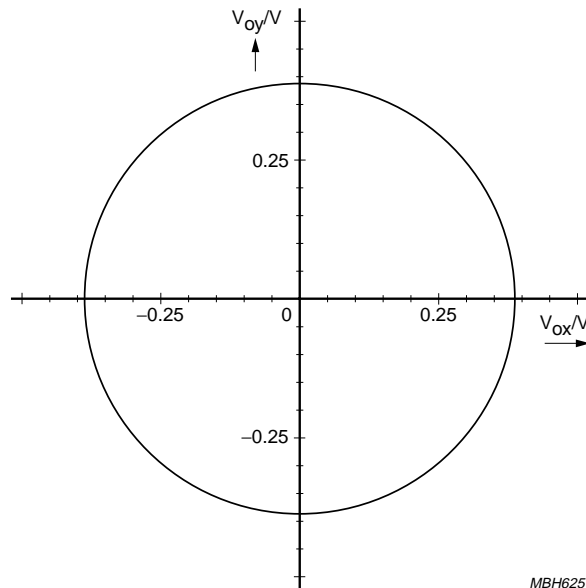

Fig.36 Typical test-diagram.

EARTH GEOMAGNETIC FIELD COMPENSATION IN CRTS

The Earth's geomagnetic field has always caused problems for TV and monitor manufacturers, as it influences the trajectory of electrons in a CRT tube producing a horizontal tilt in the geometry and convergence error shifts. With the introduction of wide screen picture tubes, this problem has become unacceptable, especially with geometric test patterns and 16:9 aspect ratios. With the continuing goal of improving picture quality and allowing for varying magnetic fields in every part of the world, a compensation circuit was required to reduce this effect.

A simple one-dimensional solution is to wrap a DC-current carrying coil around the neck of the CRT to generate a magnetic field opposite to the Earth's field, cancelling the twist in the electrons path and reducing by approximately 50% the number of convergence errors.

This coil also has the additional advantage of compensating for any other extraneous electromagnetic field sources emanating from the TV such as the loudspeakers. By including a magnetoresistive sensor to detect the Earth field, the output from the sensor can be used to drive the compensation field, making adjustment automatic.

Although residual picture twist and North/South trapezoid errors can still be seen, a simple DC-shift in the compensation current will eliminate the picture twist and the addition of a vertical sawtooth (ramp) current, derived from the vertical deflection, will remove the N/S trapezoid.

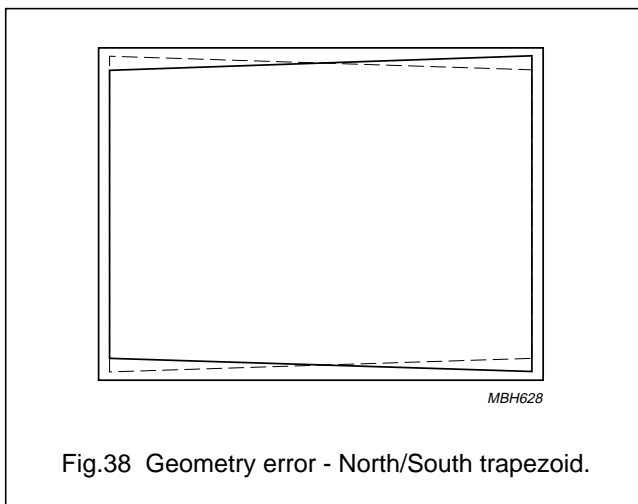
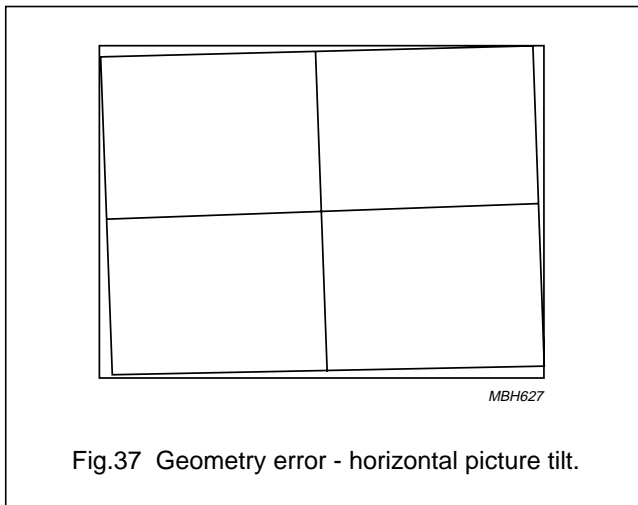

TRAFFIC DETECTION

As the number of vehicles using already congested roads steadily increases, traffic control systems are becoming necessary to avoid time consuming traffic jams. These systems monitor traffic flow, average speed and traffic density, allowing electronic road signs to control the flow and speed of traffic at known trouble spots. They also have the advantage of indicating possible incidents, where traffic speeds fall significantly below average on certain sections of road. Simple modifications to these systems allows them to be used to improve safety, and also to monitor ground traffic at airports.

Although highly sophisticated computer systems are used to analyse the various inputs in traffic systems, currently this input information is gained from inductive systems which have a number of disadvantages. The low sensitivity offered by inductive measuring systems requires large areas of road to be lifted and re-surfaced during installation. With their high power consumption, and the fact they produce very little information regarding the type of traffic passing over them, makes them both costly and inefficient. They are also rather unreliable due to road thermal stress.

As practically every vehicle manufactured contains a high number of ferromagnetic components, a measurable magnetic field specific to an individual model from every manufacturer can be detected, using weak field measurement techniques with magnetoresistive sensors. Even with the greater use of aluminium in manufacture and if the vehicle has been demagnetized, it will still create a measurable change in geomagnetic field strength and flux density.

In comparison with inductive methods, with its high sensitivity magnetoresistive measuring can provide information on the passing vehicle type. Also, due to the sensor size and placement, systems can be easily and quickly installed in any stretch of road, or even by the side of the road, if necessary. Combined with almost negligible power consumption, this makes magnetoresistive control systems an inexpensive and highly efficient method of monitoring traffic levels.

A. Measurements on roads

A field test with three-dimensional sensor modules was set-up, firstly to measure the signals of different vehicles; and secondly, the relative occurrence of signal values of three vehicle categories (car, van and truck). For the first test, one module was placed in the road, under the vehicle and for comparison, a second module was placed at the side of the road. For the second test, which was performed 'live' on a street in Hamburg, Germany, the module could only be positioned at the side of the road.

The local geomagnetic field was calibrated to zero, so that only the disturbance in the field caused by the passing vehicle would be recorded. Figure 39 shows the spectra produced by an Opel Kadett.

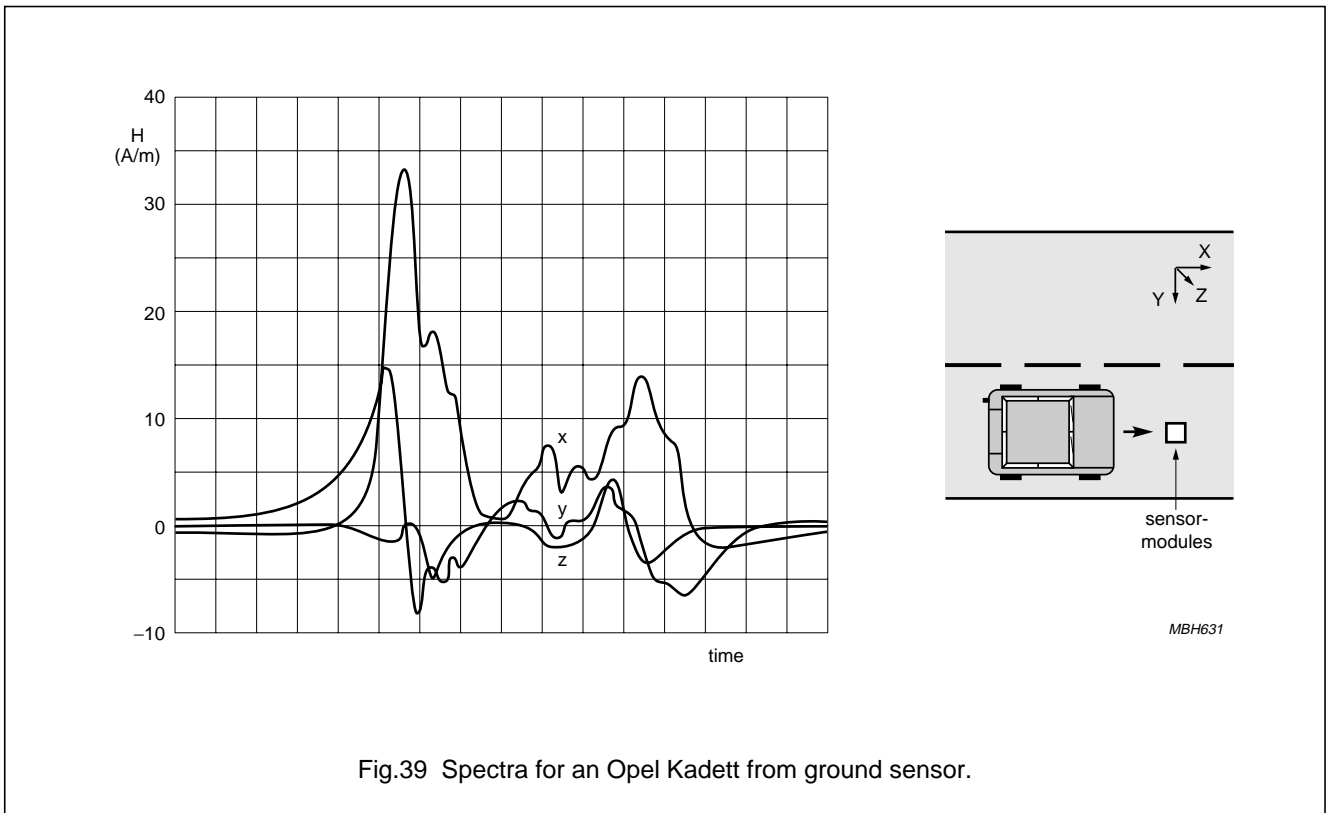
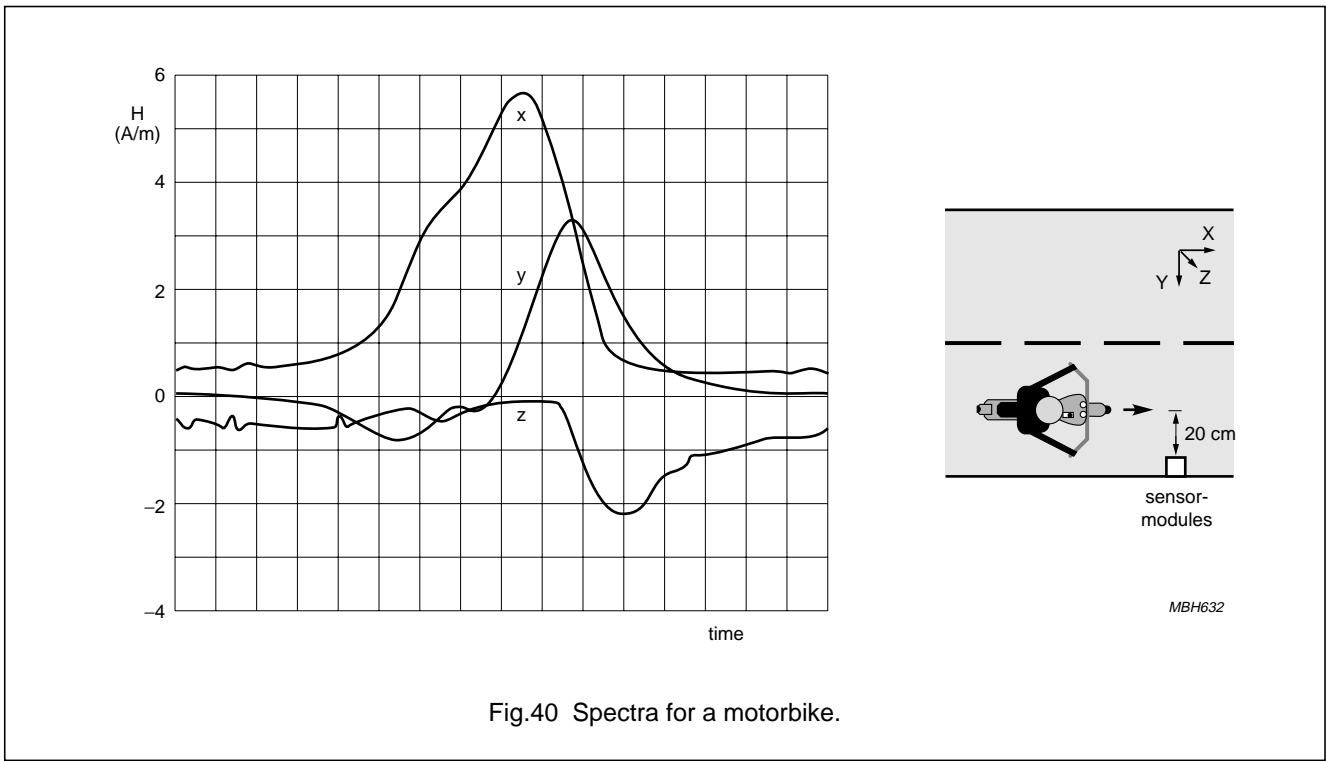

Fig.39 Spectra for an Opel Kadett from ground sensor.

The sensor modules also proved sensitive enough to detect and distinguish motorbikes (even with engine, frame and wheels being made of aluminium), which produced the following roadside spectra.

Magnetic field sensors

General



For the roadside test in Hamburg, the road was chosen at random and the maximum signal value was recorded for different vehicles, being grouped into cars, vans and trucks. The relative occurrence of signal values are shown in the following diagram.

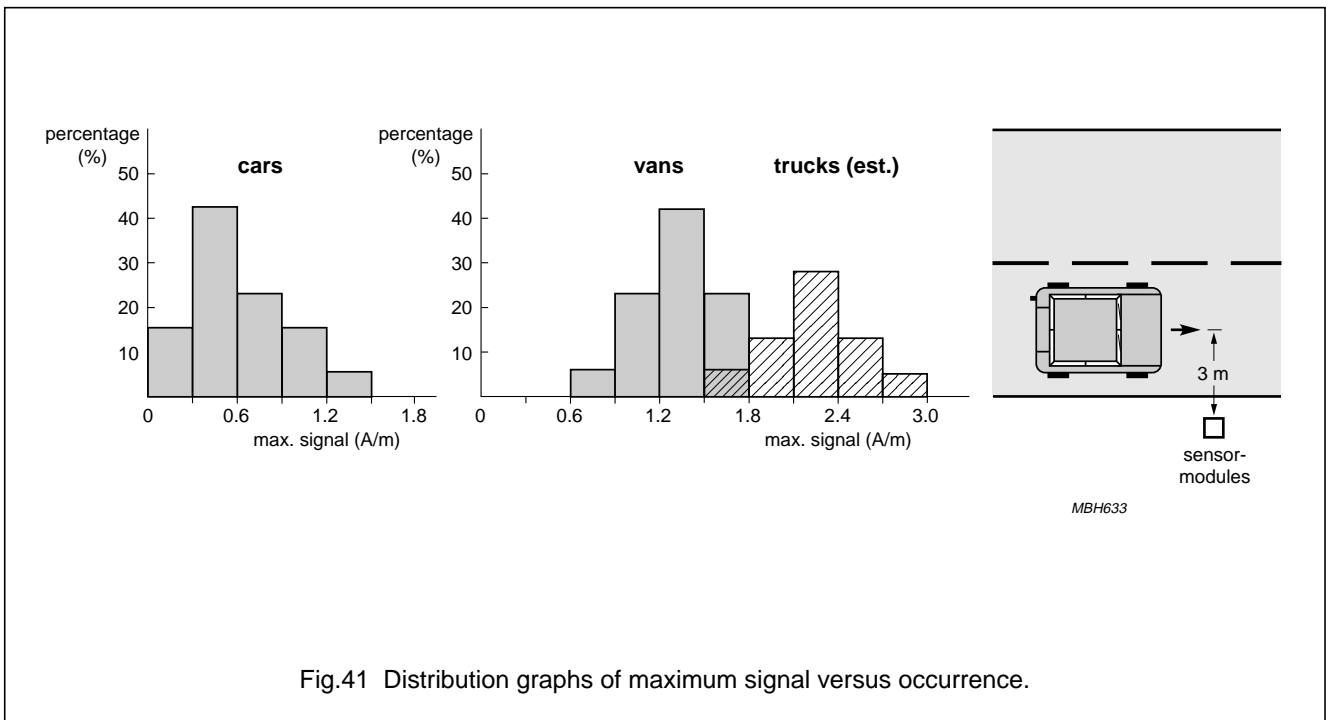

Magnetic field sensors

General

The signals in each group seem to have a Gaussian distribution with a characteristic maximum (although in fact there were only three trucks, so the values for this group are an estimate).

B. Airport ground traffic control

With the constant growth in air traffic around the world, one serious consideration in the improvement of safety and the ability to improve the handling capacity of airports, is the control of traffic on and around runways. Using a traffic control system, it is possible to introduce automatic guidance systems and prevent runway incursions even at heavily congested airports or under low visibility conditions, in accordance with regulations set-down by the internationally recognized authorities.

Although there are a number of possible sensor solutions, traffic systems using magnetoresistive technology have none of the drawbacks of existing radar, microwave, I/R, pressure, acoustic or inductive systems (see Table 6). They meet all of the functional and environmental restraints, such as large temperature ranges, insensitivity to climatic changes, low power consumption and, most of all, low cost, high reliability and ruggedness. They can also perform a range of signalling functions including detection of presence, recognition, classification, estimation of speed and deviation from path.

Table 6 Disadvantages of various sensors for airport ground traffic control units

Radar	Microwave barriers	Inductive sensors
<ul style="list-style-type: none"> • High costs • Reduced efficiency with large number of targets • Line of sight only • Complex target identification • Low resolution • Slow response times 	<ul style="list-style-type: none"> • Cannot be installed flush with the ground • Creates new obstacles in surveyed area • Produce EM interference 	<ul style="list-style-type: none"> • Low sensitivity and short range • Poor target information • High power consumption • Unreliable in harsh environments • Repairs require traffic to be stopped or diverted
Pressure sensors	Acoustic sensors	I/R signalling
<ul style="list-style-type: none"> • Frequent mechanical breakdowns when used in harsh environments • Associated ageing problems • Poor target identification 	<ul style="list-style-type: none"> • Signal interference when used outdoor and due to weather conditions • Trade-off between sensitivity and range • Large power consumption 	<ul style="list-style-type: none"> • Greatly affected by weather conditions • Complex target identification

CURRENT MEASUREMENT

Contents:

- Principles
- Some practical sensing set-ups
- Measurement examples using Philips' sensors.

Principles

The principle of measuring current with a magnetoresistive sensor is straightforward. As a current, *i*, flows through a wire, it generates a magnetic field around it which is directly proportional to the current. By measuring the strength of this magnetic field with a magnetoresistive sensor, the current can thus be accurately determined.

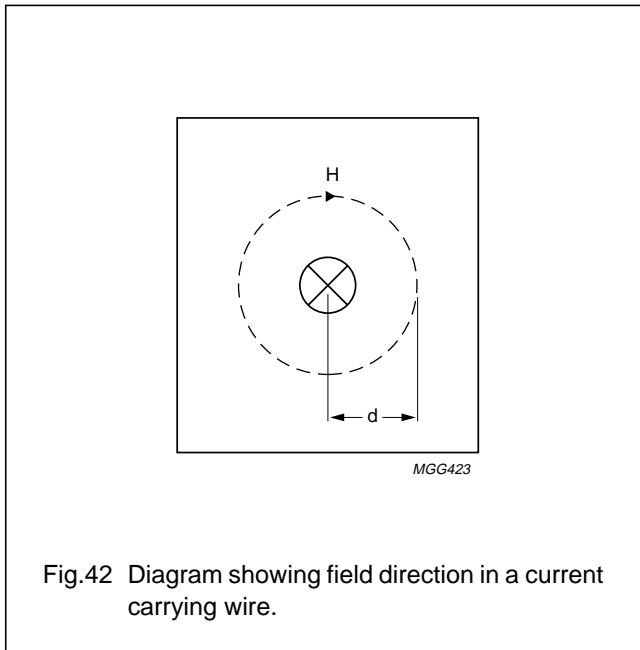

Fig.42 Diagram showing field direction in a current carrying wire.

The relationship between magnetic field strength *H*, current *i* and distance *d* is given by:

$$H = \frac{i}{2\pi d} \tag{14}$$

Some calculated values of *H* for typical conditions are given in Table 7.

Table 7 Values for the magnetic field generated by a current carrying wire at various distances and currents

EXAMPLE	CURRENT (i)	DISTANCE (d)	MAGNETIC FIELD (H)
1	10 mA	0.5 mm	3.18 A/m
2	1 A	0.5 mm	318 A/m
3	1000 A	10 mm	15.9 kA/m

Table 7 clearly indicates that current measurement can involve measurement of weak or strong magnetic fields. As the sensitivity of magnetoresistive sensors can easily be adjusted, using different set-ups and different electronics (refer to the selection guide in the General section), an individual sensor can be optimized for a specific current measurement application, a clear advantage over Hall effect sensors.

The accuracy achievable in current measurement using magnetoresistive sensors is highly dependent on the specific application set-up. Factors which affect accuracy are mechanical tolerances (such as the distance between the sensor and the wire), temperature drift and the sensitivity of the conditioning electronics. However, with Philips magnetoresistive sensors accuracies to within about 1% are possible.

There is a general difference in the set-up used when using MR sensors for AC or DC current measurement, due to the effects of disturbance fields such as the Earth's geomagnetic field. For AC currents, disturbing fields can be eliminated using filtering techniques (similar to those described in the Chapter "Weak field measurements"), while for DC currents, compensation techniques must be used (for example by using two sensors).

Some practical sensing set-ups

DIRECT MEASUREMENT WITH A SINGLE SENSOR

Philips' sensors can be used in a number of standard set-ups for current measurement. The simplest places a single sensor close to the current carrying wire, to measure directly the field generated by the current (see Fig.43). Figure 44 shows how the sensitivity of the sensor varies with distance from the wire.

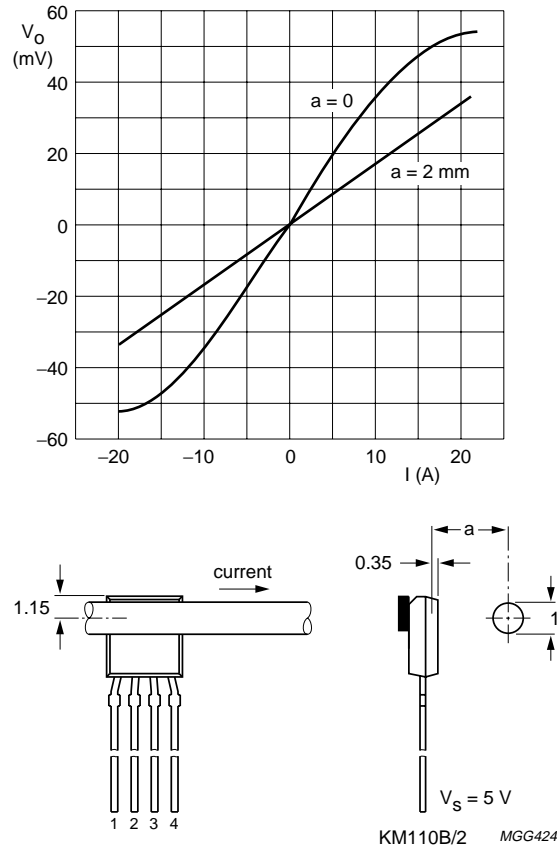

Fig.43 Simple set-up for measuring current using a KM110B/2 sensor with an external magnet.

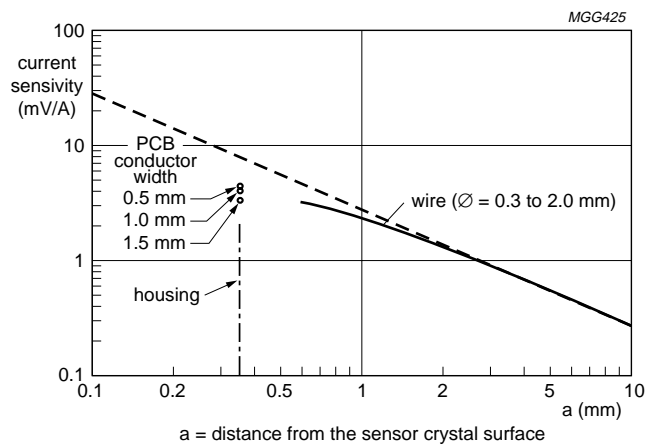

Fig.44 Sensor sensitivity versus distance for wires with diameters ranging from 0.3 to 2.0 mm.

Not surprisingly, sensor sensitivity rises as distance 'a' decreases. For relatively large values of 'a' (say 5 mm), the increase in sensitivity is substantially linear, but at closer spacings, when the magnetic field generated by the current is no longer uniform over the sensor, the rate of increase drops off. For higher currents, a similar drop off from linearity would be observed at quite large distances, but this is due to the magnetic field generated by the current saturating the sensor. In this case, an optimal linear relationship can be simply restored by using a less sensitive sensor (refer to Table 2 in the 'General introduction' for a summary of Philips sensors and their main characteristics).

The sensor can also be laid directly onto the conductor in a PCB and Fig.44 also shows the sensitivity of the sensor for three widths of PCB conductor.

IMPROVING ACCURACY WITH A FERRITE CORE

A second set-up, shown in Fig.45, is a more sophisticated arrangement in which the magnetic field generated by the current-carrying wire is compensated by a secondary circuit wrapped around a ferrite core. At the 'null-field' point, detected by the sensor located in the air gap between the ends of the core, the magnitude of the current in the secondary circuit is a measure of the current in the main circuit. This arrangement provides a more accurate means of measuring current, reducing any inaccuracies as a result of tolerances, temperature drift and slight non-linearities in the sensor characteristics, lending itself more to precision applications.

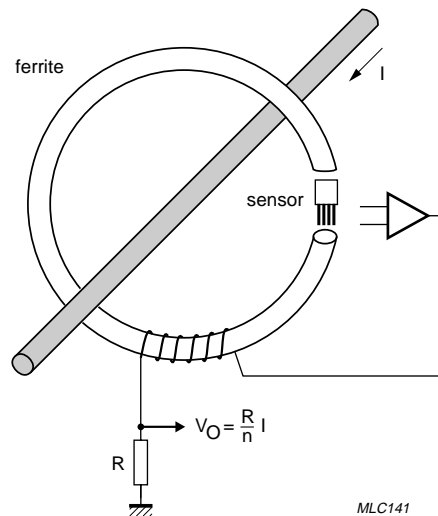

Fig.45 Current measurement using a compensating coil.

Both these first two set-ups allow current measurement without breaking the conductor or interfering with the circuit in any way, providing a distinct advantage over resistor based systems. They can be used, for example, for measuring the current in a headlamp-failure detection system in motor vehicles or in clamp-on (non-contacting) meters, as used in the power industry.

For applications where an analog signal is measured, such as in these two measurement set-ups, a good evaluation circuit should be used to allow for temperature drift compensation and for offset and sensitivity adjustment. This applies generally to measurement circuits using magnetoresistive sensors. This is discussed in more detail in Chapter "Weak field measurements".

COMPENSATING FOR EXTERNAL MAGNETIC FIELDS

In any measurement set-up, there are always other magnetic fields present besides that generated by the current, such as the earth's magnetic field, and these interfere with the measurement. A more accurate measurement set-up uses two magnetic field sensors, to compensate for these external fields (see Fig.46).

The first sensor detects both the interference field and the current-field in the positive direction, and the second sensor detects the interference field in the negative direction and the current-field in the positive direction. These two signals are added, cancelling out the interference field, leaving a signal that is representative of only the current-field.

This set-up works with homogeneous interference fields like that from the earth. Inhomogeneous fields, which will produce different interference fields inside the two sensors, will still affect the current measurement. This error can be minimized by keeping the distance between the sensors small or integrating both sensors onto a single piece of silicon. Large magnetic fields which fall outside the range of the sensors can also produce errors, so the size of external fields must be limited.

Another advantage of using two sensors, at a fixed distance apart, is that measurement is less sensitive to sensor-conductor distance. If the conductor is moved closer to the first sensor, then its distance from the second sensor is correspondingly increased and the effect is compensated. For small differences in distance between the conductor and sensors, sensitivity is nearly constant and the conductor need not be fixed in place. This method lends itself to measurement of current in free cables.

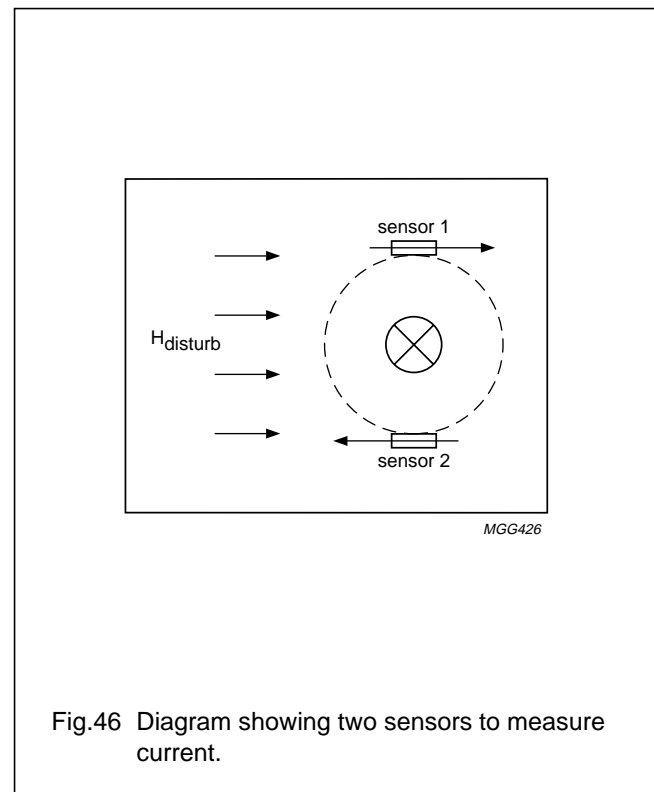

Fig.46 Diagram showing two sensors to measure current.

Table 8 summarizes the various advantages and disadvantages of one-sensor and two-sensor measurement set-ups as described above.

Magnetic field sensors

General

Table 8 Summary of advantages and disadvantages of typical measurement set-ups

CURRENT MEASUREMENT WITH TWO MAGNETIC FIELD SENSORS		CURRENT MEASUREMENT WITH ONE MAGNETIC FIELD SENSOR	
PROS	CONS	PROS	CONS
<ul style="list-style-type: none"> • no galvanic connection • no breaking of the conductor • small physical dimensions • reduced sensitivity to sensor-conductor distance • reduced interference effects from homogeneous fields 	<ul style="list-style-type: none"> • interference effects from inhomogeneous fields • errors generated from large external fields 	<ul style="list-style-type: none"> • no galvanic connection • no breaking of the conductor • small physical dimensions 	<ul style="list-style-type: none"> • effects of interference from external fields • sensitive to the sensor-conductor distance

Measurement examples using Philips' sensors

For measurement, Philips' KMZ10A/B/C and KMZ51 sensor types can be used. The KMZ10A/B/C have to be stabilized with auxiliary magnets, for example as in the KM110B/2. KMZ51 sensors contain internal conductors ('coils') to compensate for offset and temperature drift and do not need an auxiliary magnet, allowing for simple circuitry with reduced need for adjustments. As these sensors do not measure fields above about ± 230 A/m (approx. ten times the earth's magnetic field), they must be used in a measurement set-up that reduces the effects of interference fields, as described above.

The following examples demonstrate Philips' magnetoresistive sensors being used in real-life situations.

AC CURRENT MEASUREMENT USING DUAL KM110B/2 SENSORS

Two KM110B/2 sensors, placed as outlined above, are in-phase for current measurement and antiphase for external field compensation, eliminating the effects from stray fields and improving sensitivity (see figs 47 and 48).

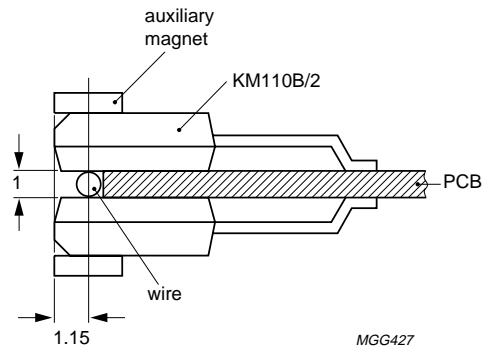

Fig.47 Diagram showing set-up for AC current measurement.

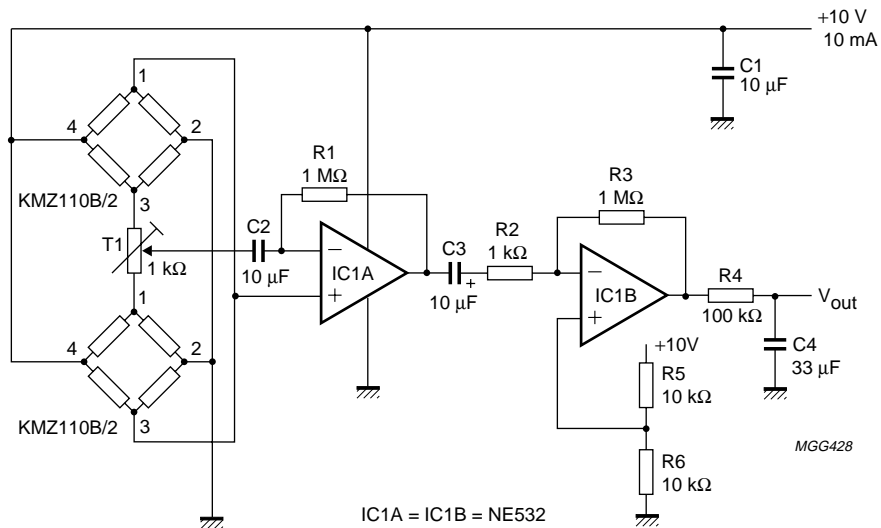

Fig.48 Circuit diagram.

Magnetic field sensors

General

This circuit shown in Fig.48 is a pre-tested design for 50 Hz currents, delivering very high sensitivity. Two KM110B/2 sensors are connected in parallel, with T1 aligned such that the signals produced by external disturbing fields is minimized. The output signal is then amplified and DC signal components are considerably reduced with filtering, through R1-C2 and R2-C3. This circuit gives the following characteristics:

Amplification: 120 dB (50 Hz)

Sensitivity: 5 V/mA

Noise level: 0.37 V

Max. output: 2.1 V (@ 0.4 mA measured current)

If R1 is adjusted to about 39 k Ω , this changes the data to:

Amplification: 92 dB

Sensitivity: 0.2 V/mA

Noise level: 0.015 V

Max. output: 2.1 V (@ 10 mA measured current)

SENSITIVE MEASUREMENT USING WEAK FIELDS WITH DUAL KMZ51 SENSORS

This section describes a practical set-up that can be used for measuring currents in the metal tracks of a PC-board. Using the paired sensor approach again, the following set-up can also be used to measure currents producing only weak magnetic fields. In this case, the conductor is also locked mechanically to the sensors, eliminating variations due to the movement of the conductor and allowing small currents to be measured to an accuracy of approximately 1%, with no galvanic connection.

Note: since this involves the measurement of weak magnetic fields, techniques must be used to suppress the influence of sensor offset and temperature drift. For more detailed information on these techniques, refer to the sections on Flipping and Compensation in Chapter "Weak field measurements".

Generally there are several sensor set-ups which can be used to compensate for the external field. If there are components on both sides of the PCB, the set-up in Fig.49 can be used.

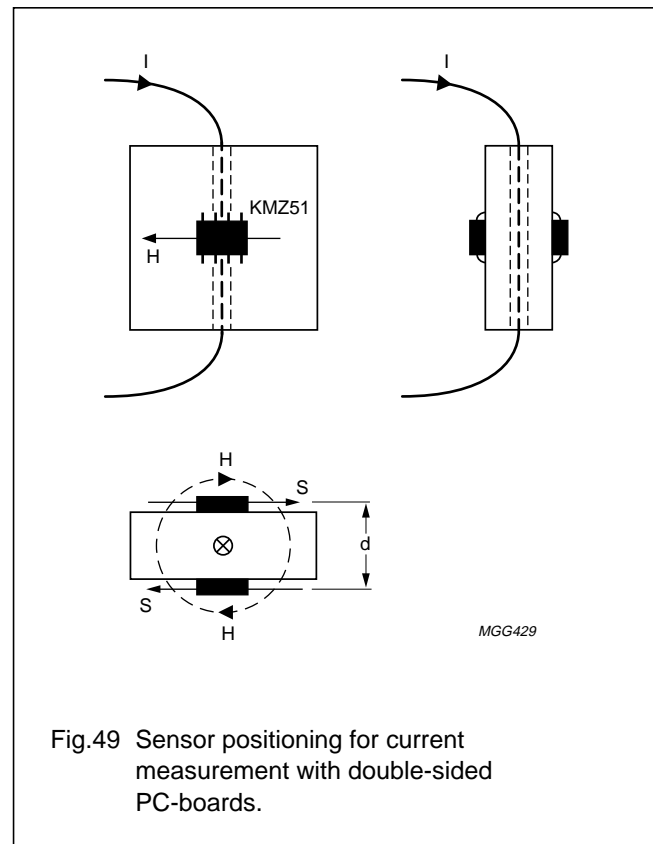

Fig.49 Sensor positioning for current measurement with double-sided PC-boards.

The current carrying track is in the centre of the board with the sensors' sensitive direction marked with an 'S'. This set-up clearly follows the conditions described in Section "Compensating for external magnetic fields" earlier (see also Fig.46).

If components are only placed on one side of the PCB, then the track carrying the current to be measured must be laid in such a way that the conditions described in Section "Compensating for external magnetic fields" are adhered to. Figure 50 illustrates three possible set-ups of sensor and current-carrier, used in Philips Semiconductors' demonstration board.

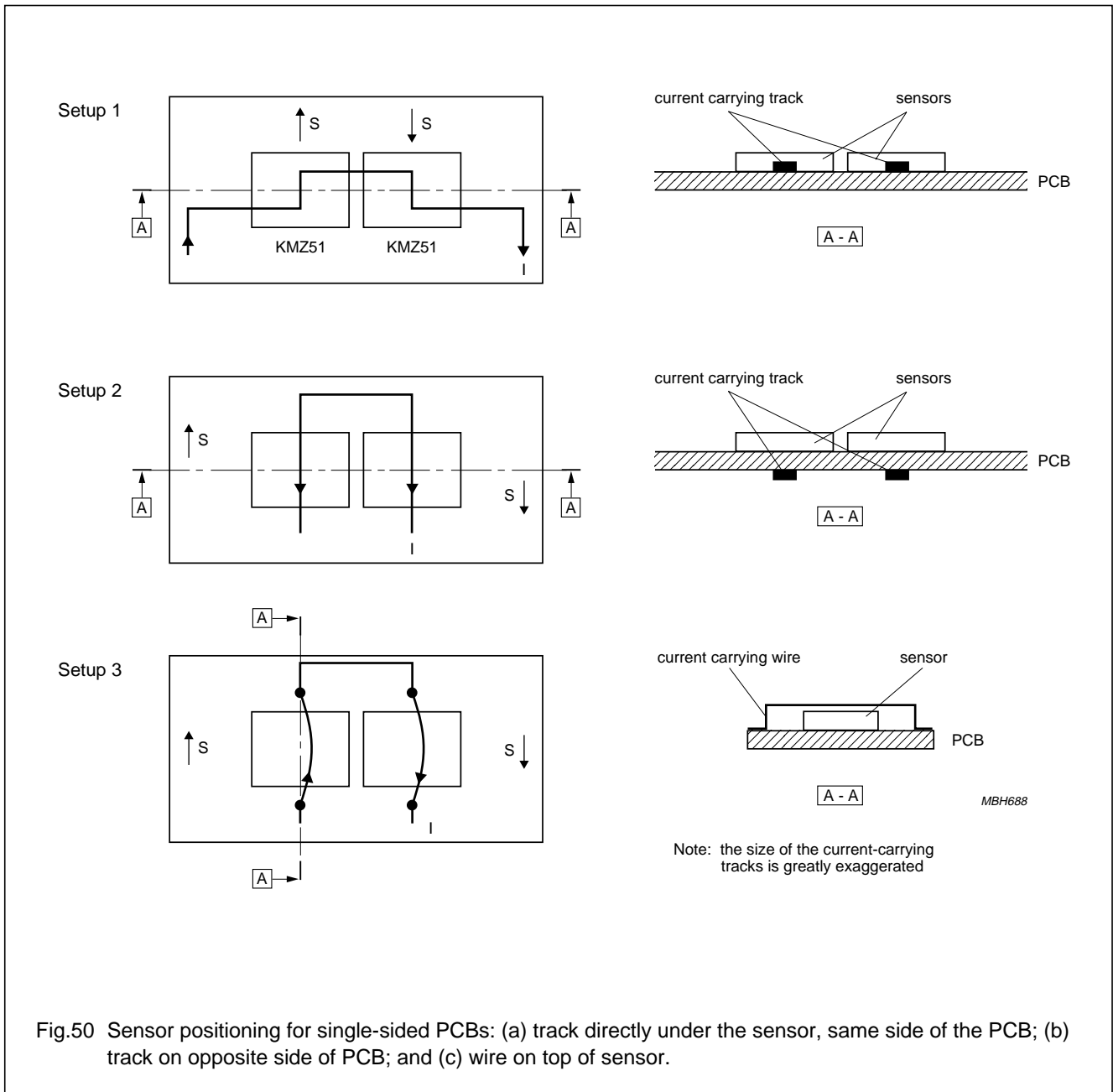

Fig.50 Sensor positioning for single-sided PCBs: (a) track directly under the sensor, same side of the PCB; (b) track on opposite side of PCB; and (c) wire on top of sensor.

The circuitry used to condition the sensor output to a usable signal (see Fig.51) can be the same for all three set-ups. The basic principle is to have the sensors electrically parallel, effectively merging the output signals. This gives the following advantages that

- Only one conditioning circuit is required for both sensors
- The sensors themselves automatically compensate for any disturbing fields.

Magnetic field sensors

General

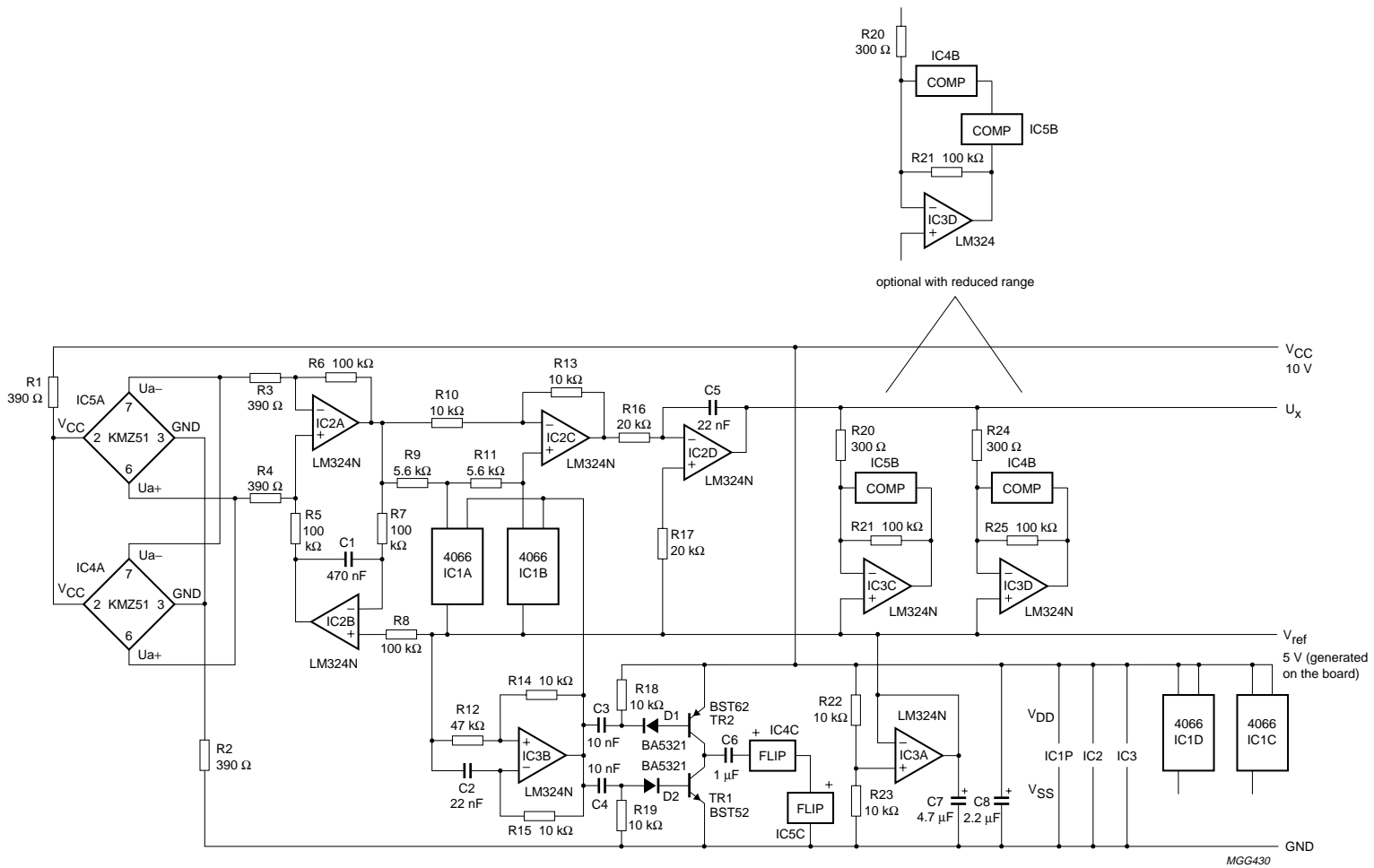

Fig.51 Circuit diagram: Philips Current Measurement Testboard KMZ51.

MGG430

Magnetic field sensors

General

After the output signals of the two sensors have been merged, the basic conditioning circuitry is similar to that used for weak field measurement. The basic principles of the electronics are described in more detail in Chapter "Weak field measurements"; however, the figures quoted in that example are for a compass application and this circuit is optimized for current measurement, with the following characteristics:

Table 9

Maximum level of compensation for current and disturbing fields	± 230 A/m
$I_{comp(max.)}$	± 10 mA
Time constant	200 Hz

The sensitivities and ranges of the three different sensor set-ups shown in Fig.50 are:

- Set-up 1: 1.8 V/A; range: ± 1.1 A
- Set-up 2: 1.1 V/A; range: ± 1.8 A
- Set-up 3: 5.7 V/A; range: ± 0.35 A

Note: this example uses an analog circuit, to clarify the principles of current measurement including flipping and magnetic compensation. A large part of the functionality of the circuitry could easily be handled by a microprocessor (see Fig.52 for a typical circuit diagram).

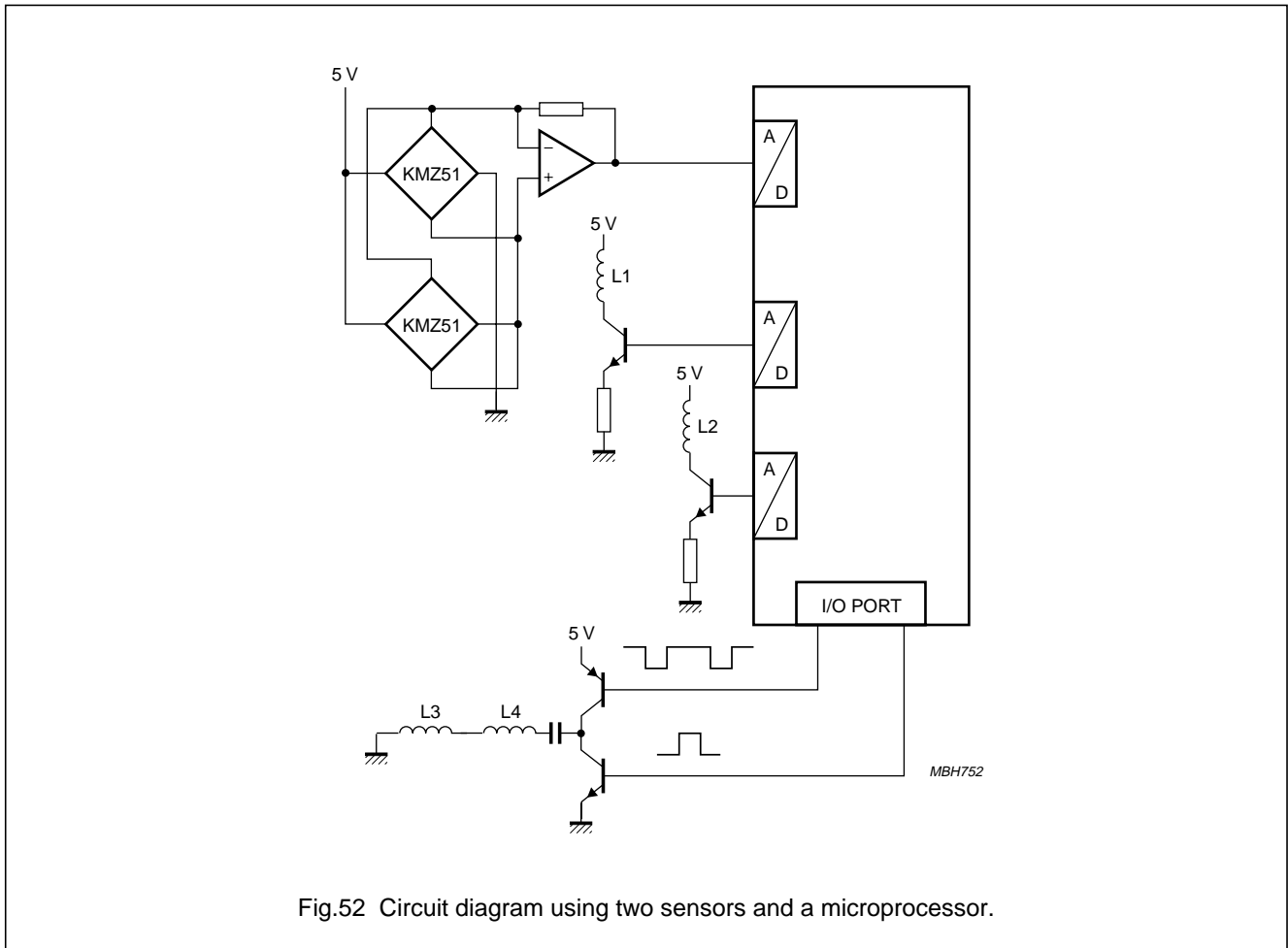

Fig.52 Circuit diagram using two sensors and a microprocessor.

Magnetic field sensors

General

HIGH DC CURRENT MEASUREMENTS

Interest in sensors for contactless measurement of high currents has been steadily increasing and to help customers apply this technology, Philips has prepared a module for testing, based on our KM110B/2 magnetoresistive sensor (equipped with a stabilization magnet). It consists of the KM110B/2 sensor, conditioning electronics and a U-core.

The wire carrying the current to be measured should be fed through the U-core, but a short distance should be maintained between the wire and the sensor. Figure 53 shows the influence of wire position on sensitivity. If wires are thin, a spacer above the sensor can prevent errors in the measurement. Cables or conductors with large diameters are less sensitive to this effect. Ring cores with an air gap are generally less sensitive to wire position but are more difficult to obtain and mount, so a U-core was used for these test modules.

Figure 54 shows the conditioning electronics for this set-up. In principle, it is similar to the basic conditioning circuit in the 'General introduction' (see Fig.11), although it has been optimized for this particular application and has the following characteristics:

- Supply voltage V_B : 5 V
- Current range: 16 A
- Frequency range: 0 to 1000 Hz
- Temperature range: -40 to +80 °C
- Sensitivity: 135 mV/A
- Sensitivity temperature drift (temperature range -20/+85 °C): < 0.8%
- Quiescent output voltage ($I = 0$ A): 2.5 V
- Quiescent output voltage temperature drift (temperature range -20/+85 °C): < 25 mV
- Equivalent current drift: < 0.2 A.

The typical response of this sensor and circuit set-up is shown in Fig.55 and shows the excellent linearity, even for large currents.

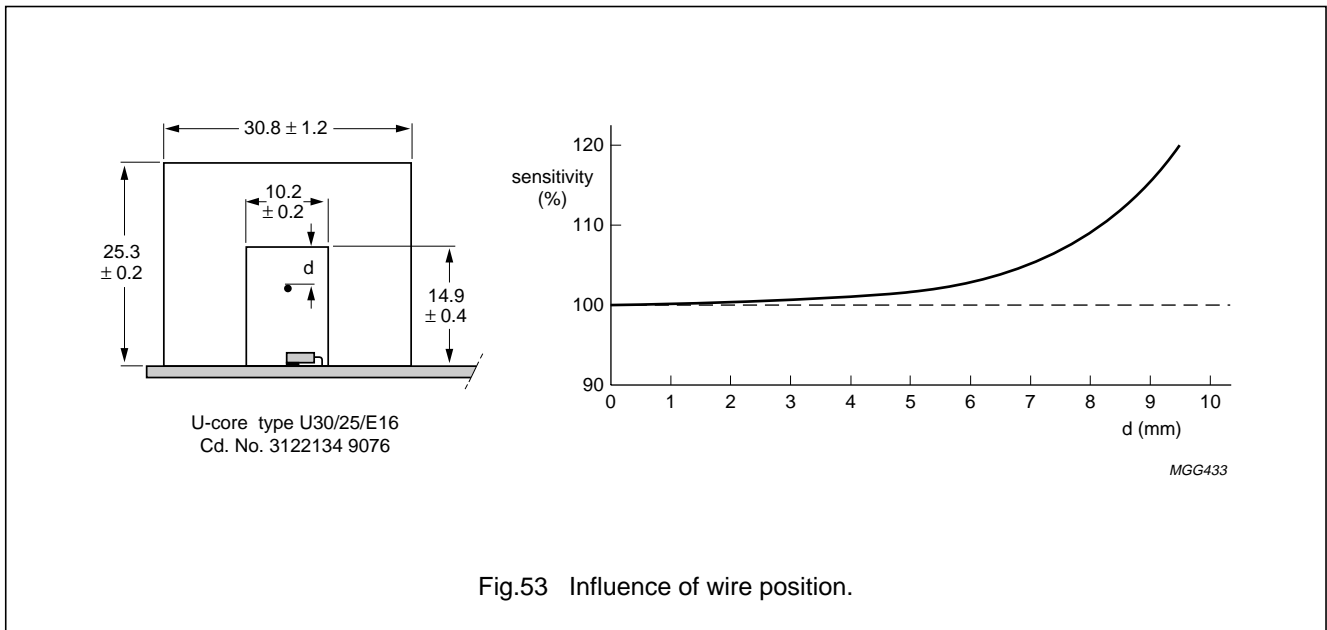

Fig.53 Influence of wire position.

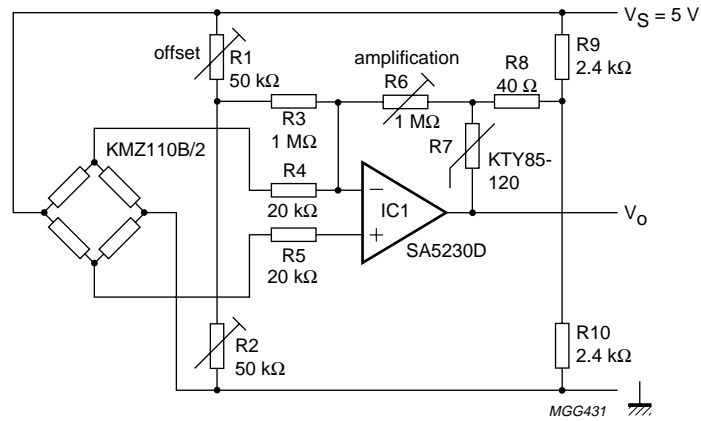

Fig.54 Circuit diagram for a current sensor based on this module.

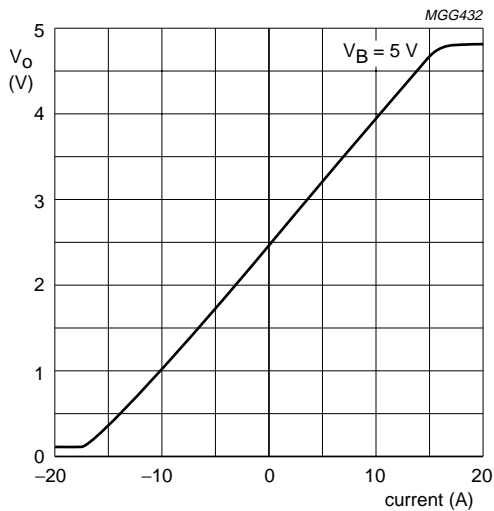

Fig.55 Typical response of a current sensor based on this module.

Other current ranges can be obtained by varying the following:

- Sensor (KMZ10C with auxiliary magnet, delivering a current range of about ± 50 A)
- Core type
- Sensor position relative to the core.

Varying these parameters as described in general produces higher current ranges. Sensitivity can also be increased by winding the wire repeatedly through the core or by applying a higher amplification range. Modules have also been prepared with higher current ranges (up to ± 300 A), using stronger auxiliary magnets. More information is available on request.

These are just a few of the possibilities offered by magnetoresistive sensors for current measurement. With their inherent simplicity of application and ability to compensate easily for disturbing fields, MR sensors are easily the most flexible choice.

LINEAR POSITION AND PROXIMITY MEASUREMENT

Contents:

- Principles and standard set-ups
- Position measurement applications
- Reference set-ups.

Principles and standard set-ups

The sensitivity of magnetoresistive sensors lends itself to linear position measurement systems, with a number of possible applications. Simple basic set-ups can be used for one-point position measurement and a linear position measurement set-up and can be easily modified to produce a proximity switch sensor.

The underlying principle is very similar to that used for angular measurement, in that as a magnet on the target is moved, the internal magnetization vectors of the permalloy strips on the sensor change, aligning themselves with the external magnetic field and thus changing their resistance.

When a magnetoresistive sensor is placed in a permanent magnetic field, generally it is exposed to fields in both the x- and y-direction. If the magnet is oriented is such a way that the axis of the auxiliary field in the x-direction is parallel to the permalloy strips in the sensor, then any movement in the y-direction can be seen as fluctuations in the transverse field, which can be equated to the position of the magnet with respect to the sensor.

The linear region of the sensor's sinusoidal output is defined roughly by the length of the magnet. Outside this area, the axial field produced by the magnet is becomes weaker and near the poles, it also changes direction, both of which can cause sensor flipping. (For further information on sensor flipping, please refer to Appendix 2 and the Chapter on "Weak field measurements").

Figure 56 shows one of the simplest arrangements for using a sensor/magnet combination to measure linear displacement.

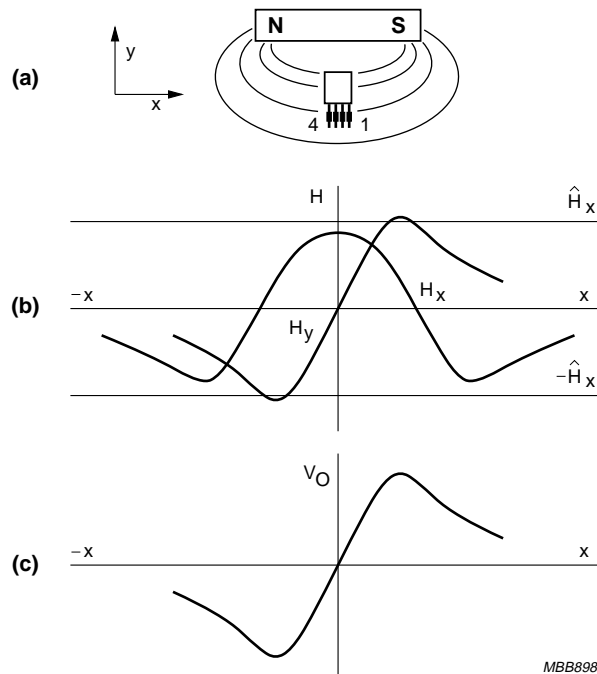

Fig.56 Sensor output in the field of a permanent magnet.

Magnetic field sensors

General

If a strong magnetic field is used or the sensor is placed very close to the magnet, there is a danger that the auxiliary field will exceed field required to flip the sensor characteristic, producing a hysteresis in sensor output (shown by the hysteresis loop ABCD in Fig.57)

This can actually be used to positive effect under certain circumstances, where temporary or fluctuating external fields may interfere with the measured signal. In this case, as long as the sensor is used in the region between D and D', the strength of the magnetic field from the permanent magnet will block out any extraneous fields.

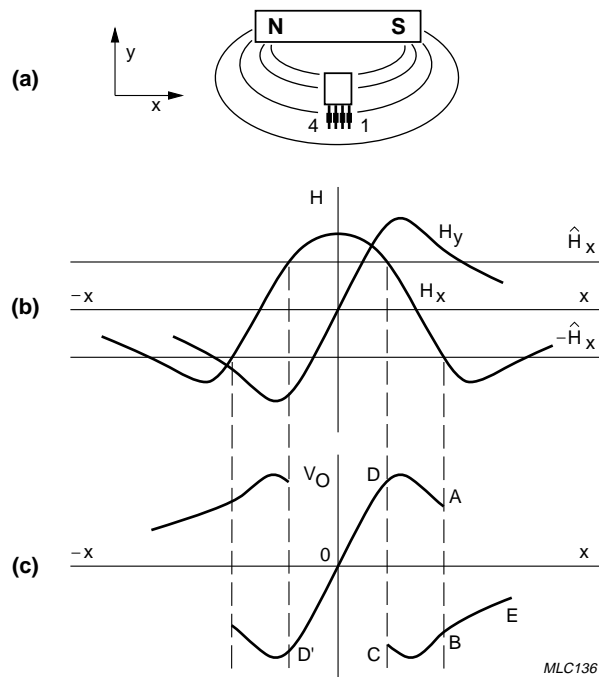

Fig.57 Sensor output in a strong magnetic field.

Magnetic field sensors

General

By orienting a sensor's axis to 45° with respect to the axis of the permanent magnet, as shown in Fig.58, it is possible to use the sensor along with a comparator, as a proximity switch. In this arrangement the sensor has a negative output, for both axial arrangements of the magnet, which can then be passed onto the inverting input of a comparator.

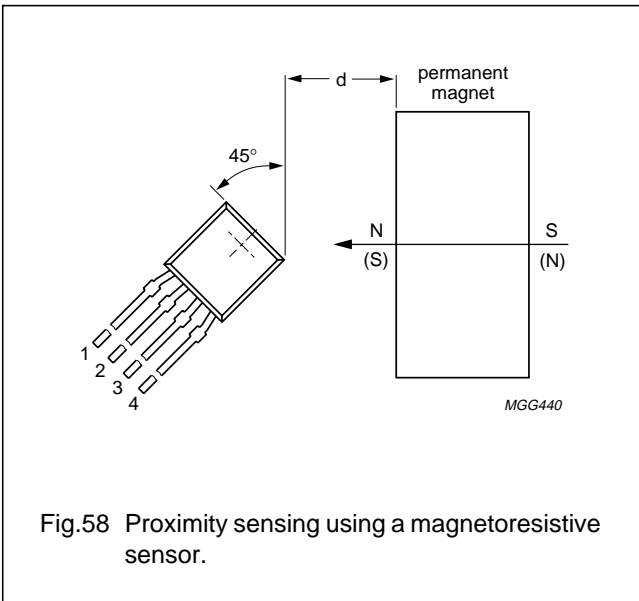

Fig.58 Proximity sensing using a magnetoresistive sensor.

The resulting output is clearly indicative of the distance 'd' between the magnet and the sensor (see Fig.59). Sensor switching levels are very important in this application; below a certain level, strong external magnetic fields may disturb the sensor sufficiently to produce ambiguous results.

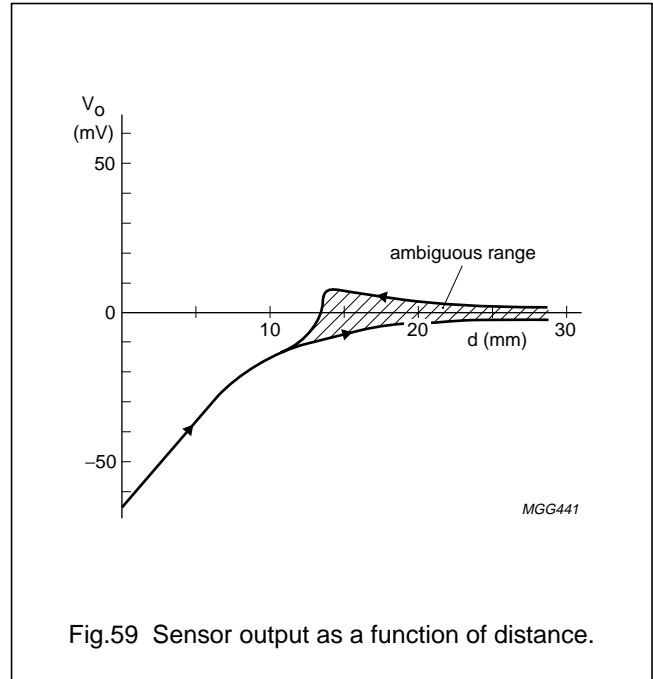

Fig.59 Sensor output as a function of distance.

Besides being used for general position sensing and measurement, by incorporating a back biasing magnet, single-point measurements are possible using any non-symmetrical region of material within the target such as a hole, pin, or region of non-magnetic material integrated into a metal plate's structure. The resulting disturbance in the magnetic field produces a variation in sensor output. Figure 60 shows the basic set-up and at the crossover point, where the hole and sensor match precisely, the sensor output is clearly independent of separation distance.

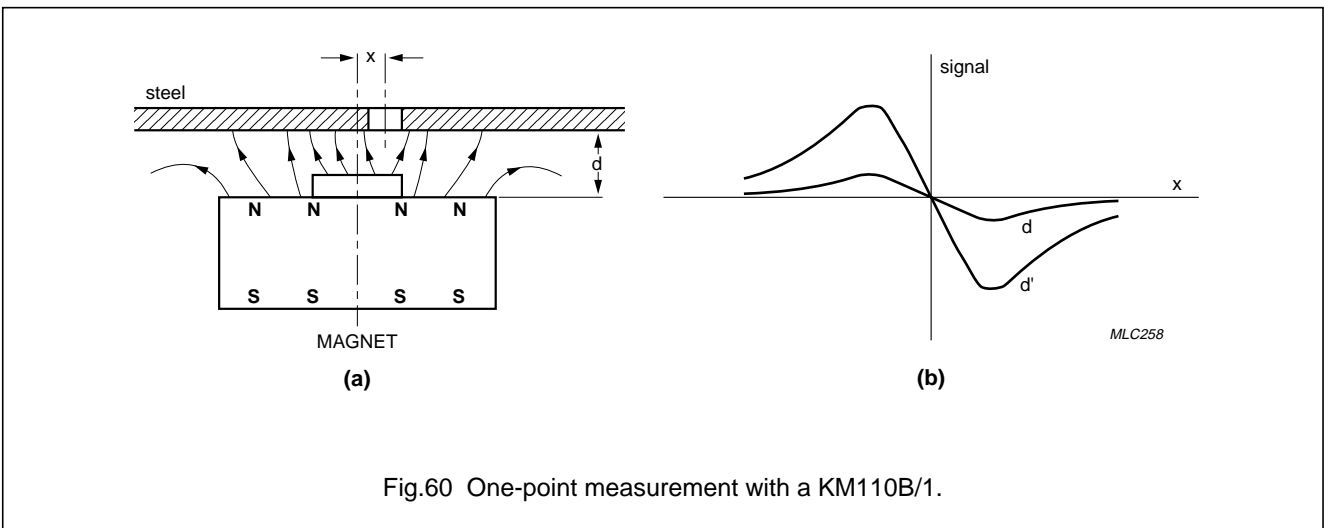

Fig.60 One-point measurement with a KM110B/1.

Magnetic field sensors

General

The obvious advantage of this technique is that the precise location of the sensor/magnet combination is irrelevant and as the sensor is basically acting as a 'null-field' detector at this point, the set-up is also independent of temperature effects. This makes the system very simple to design in.

Position measurement applications

The output from a KMZ10B and a KMZ10C sensor was measured as a function of sensor displacement, parallel to the magnetic axis. This was done using varying magnet/sensor separation distances and three different sized FXD330 magnets: a $\phi 10 \times 15$ mm, a single $\phi 4 \times 5$ mm, and two $\phi 4 \times 5$ mm placed end-to-end to make a single 10 mm long magnet. Two different set-ups were used, first with the magnetic field parallel to the sensor and second with the magnetic field perpendicular to the sensor.

MAGNETIC FIELD PARALLEL TO THE PLANE OF THE SENSOR

In this set-up the magnet is oriented with the sensor so that it is broadside-on, with its poles lying in the plane containing the sensor chip. With this arrangement, the auxiliary field is supplied by the axial field (H_x) of the magnet, which remains reasonably constant over the region of interest.

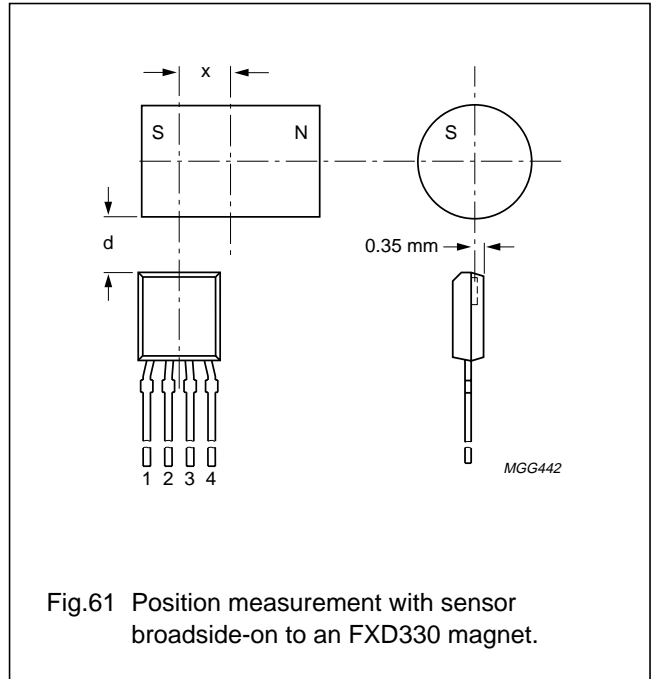

Fig.61 Position measurement with sensor broadside-on to an FXD330 magnet.

The following plots show the sensor output as a function of distance for all three magnet set-ups, with both the KMZ10B and KMZ10C.

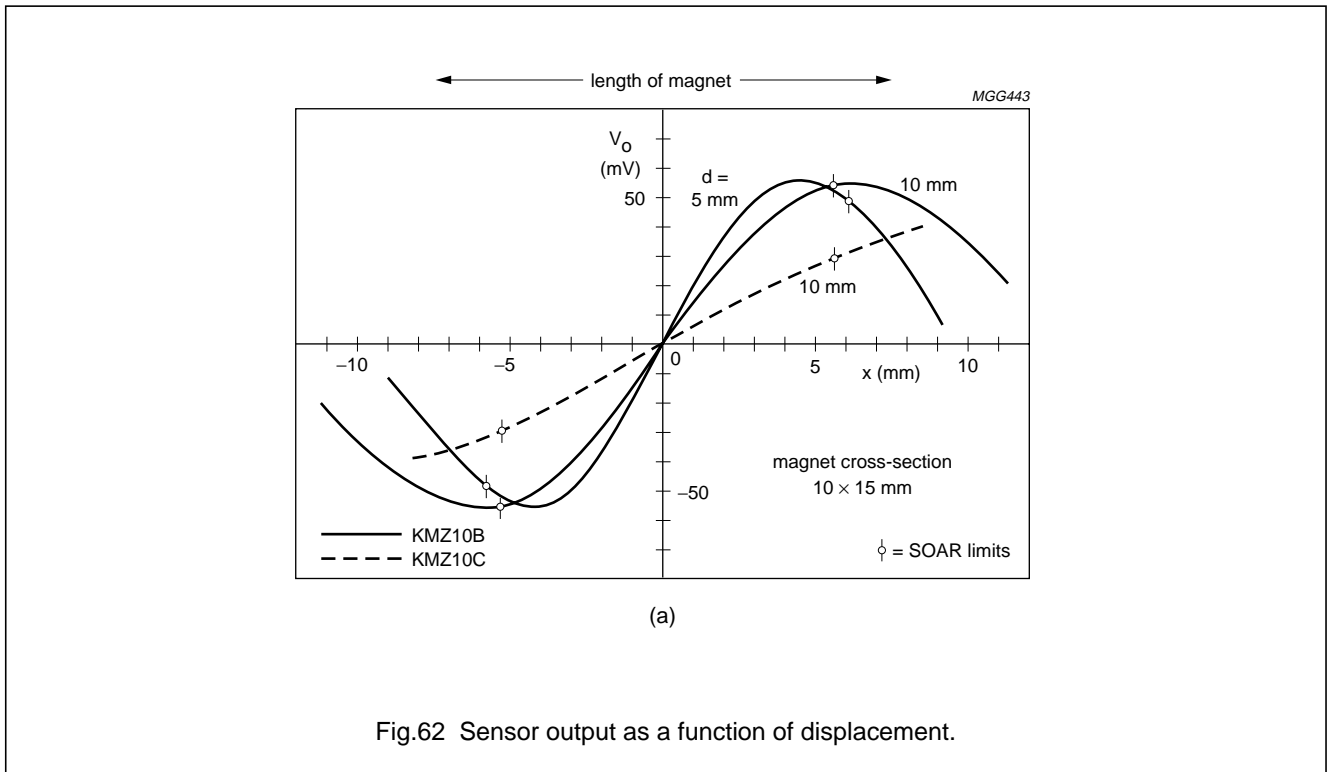
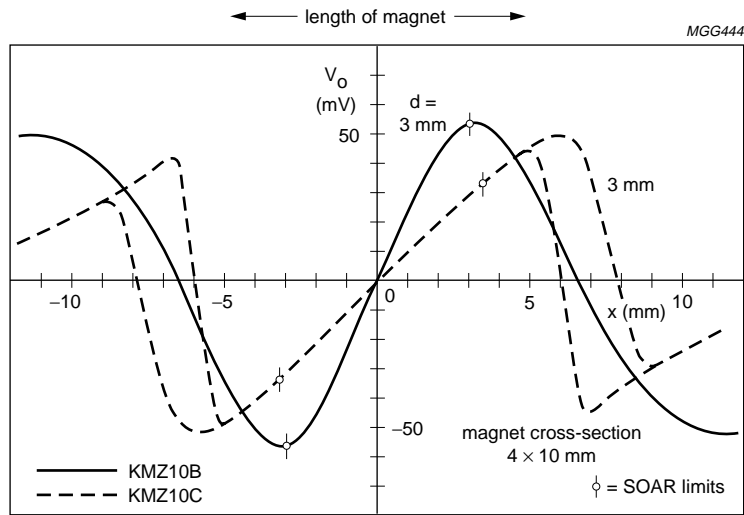
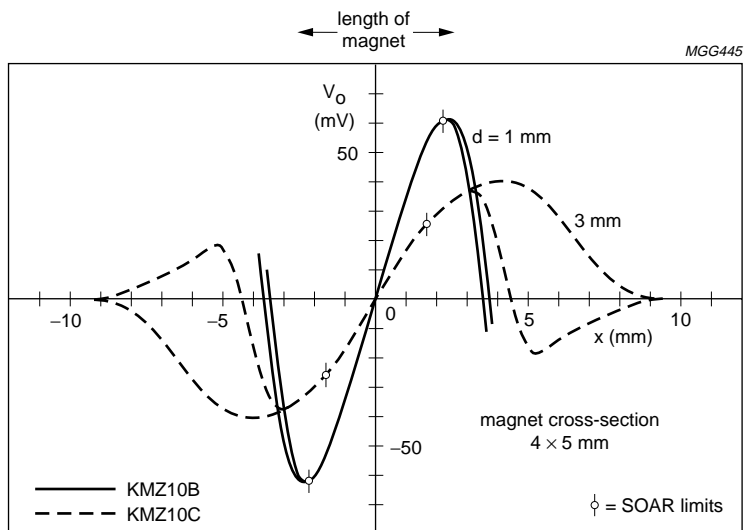

Fig.62 Sensor output as a function of displacement.



(b)

Fig.63 Sensor output as a function of displacement.



(c)

Fig.64 Sensor output as a function of displacement.

Magnetic field sensors

General

The first graph shows that as the separation distance increases, the curve flattens out. This is because as the sensor is moved closer to the magnet, the transverse field H_y of the magnet has a greater effect on the sensor, giving rise to increased rotation of the internal magnetization. As the gradient of the curve is a direct indication of the sensitivity of the sensor, then in practical application designs, sensor/magnet separation is an important factor.

From these curves it is also clear that for the KMZ10C sensor, with shorter magnets at close separation distances, switching hysteresis becomes a major factor at the limits of the sensors linear region.

MAGNETIC FIELD PERPENDICULAR TO THE SENSOR

When the sensor is oriented so that its plane is perpendicular to the magnetic axis, it is impossible for the magnet to provide the auxiliary field. In this case an additional auxiliary magnet is required, placed on the sensor as shown in Fig.65.

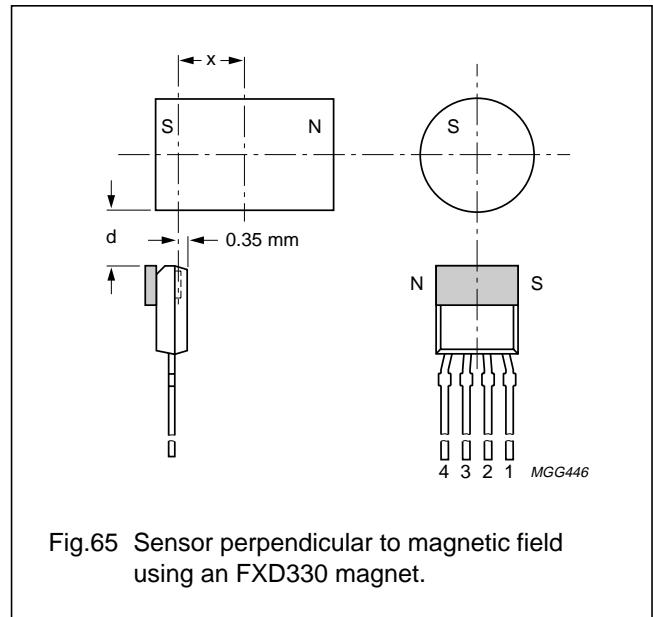

Fig.65 Sensor perpendicular to magnetic field using an FXD330 magnet.

With this set-up, the following plots were obtained using the same FXD330 magnets as with the parallel arrangement.

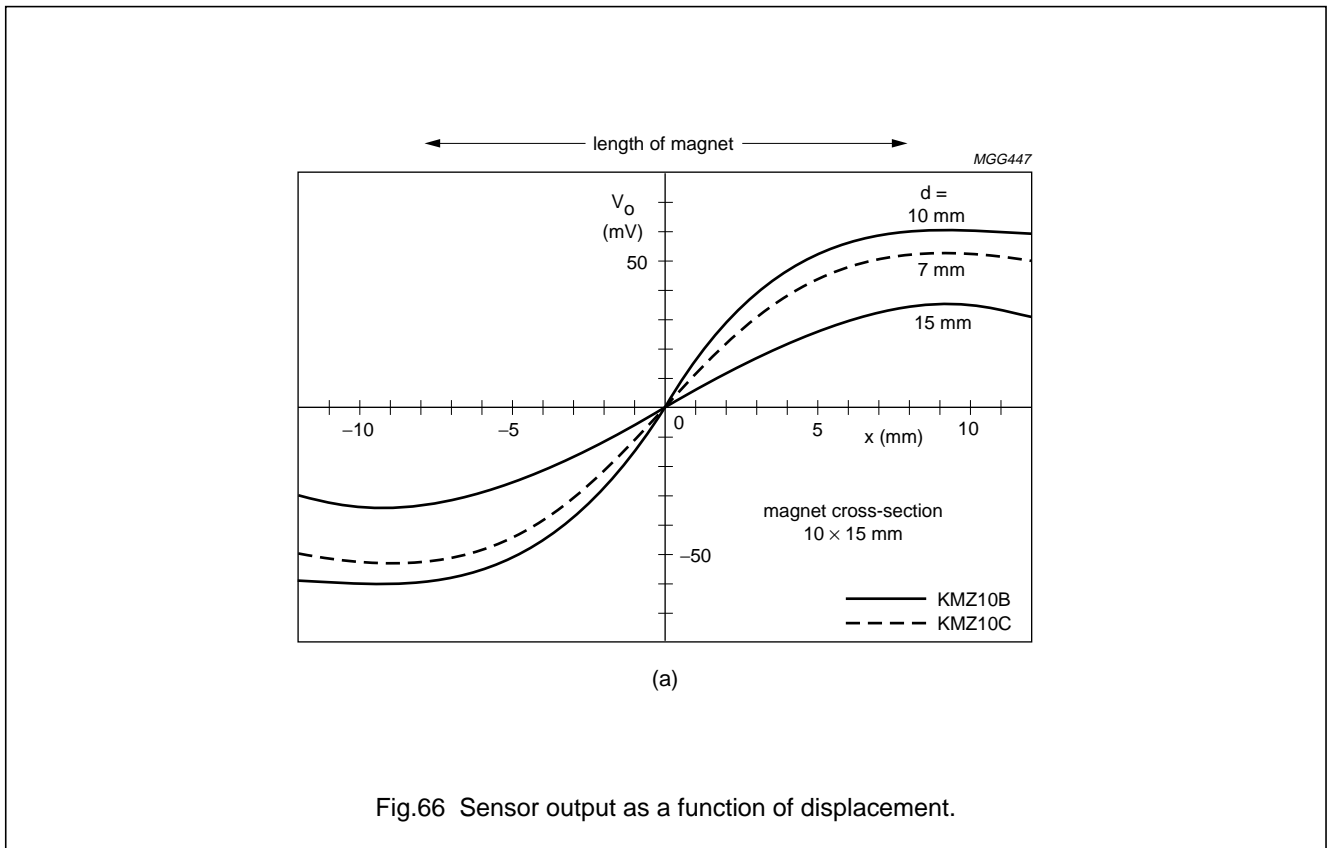

Fig.66 Sensor output as a function of displacement.

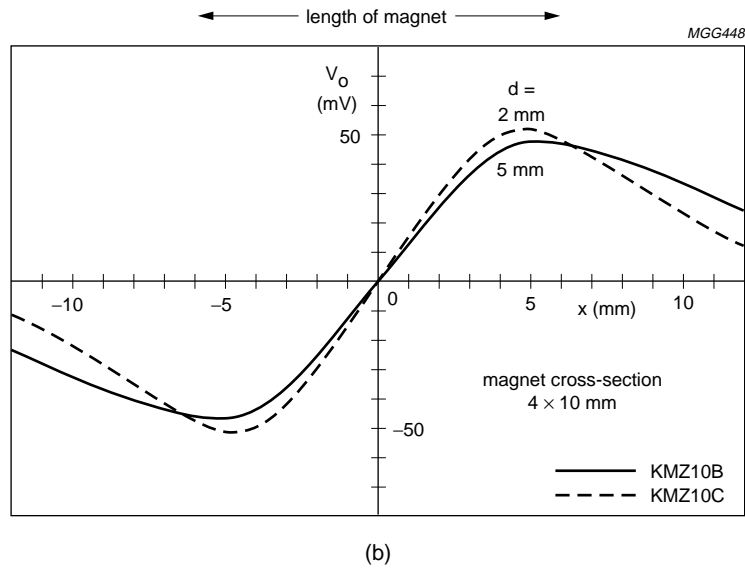

Fig.67 Sensor output as a function of displacement.

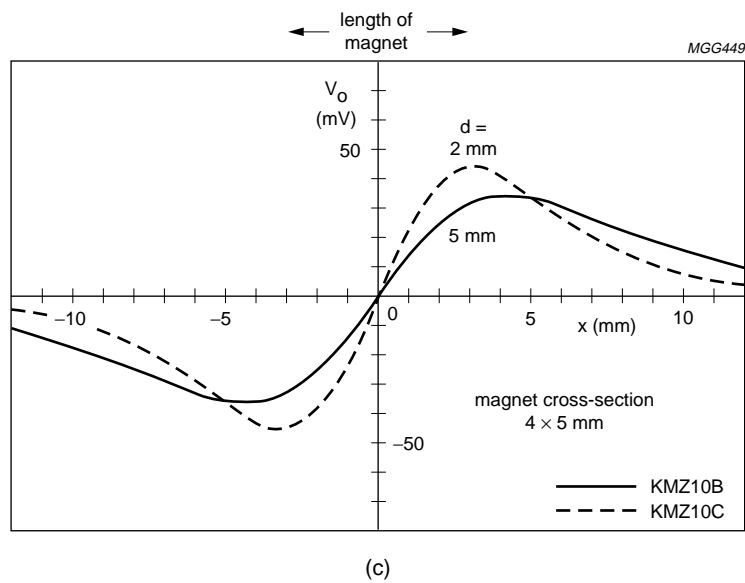

Fig.68 Sensor output as a function of displacement.

Magnetic field sensors

General

The most noticeable difference in these curves, compared to the parallel results, is the lack of hysteresis switching. This is due partly to the auxiliary magnet stabilizing the sensor and the fact that the orientation of the target magnet means it does not produce a magnetic field in the x-direction and cannot therefore adversely affect the sensor.

An interesting feature of these curves is the way the curvature changes near the ends of the magnet. This slight flattening and possible reversal of the curve can be seen more clearly when a single $\phi 4 \times 5$ mm FXD330 magnet is used with the KMZ10B sensor at very small separation distances ($d = 1$ mm).

The reason for the change in curvature is that at small distances from the target magnet, the radial field H_y at the

ends of the magnet is stronger than the field required to induce a maximum response in the sensor. This effectively saturates the sensor and the output can fall even as H_y increases.

A slightly different approach can be used for very high resolution measurements. Using a compact RES190 magnet with dimensions of $3 \times 2 \times 1$ mm, placed at the back of the sensor rather than directly above it (see Fig.70), the output of the sensor was plotted for separation distances of 1 mm, 0.5 mm and 0.1 mm.

Figure 71 clearly shows that this set-up is very well suited for high resolution or high sensitivity measurement of position at very short distances, using the linear part of the response curve.

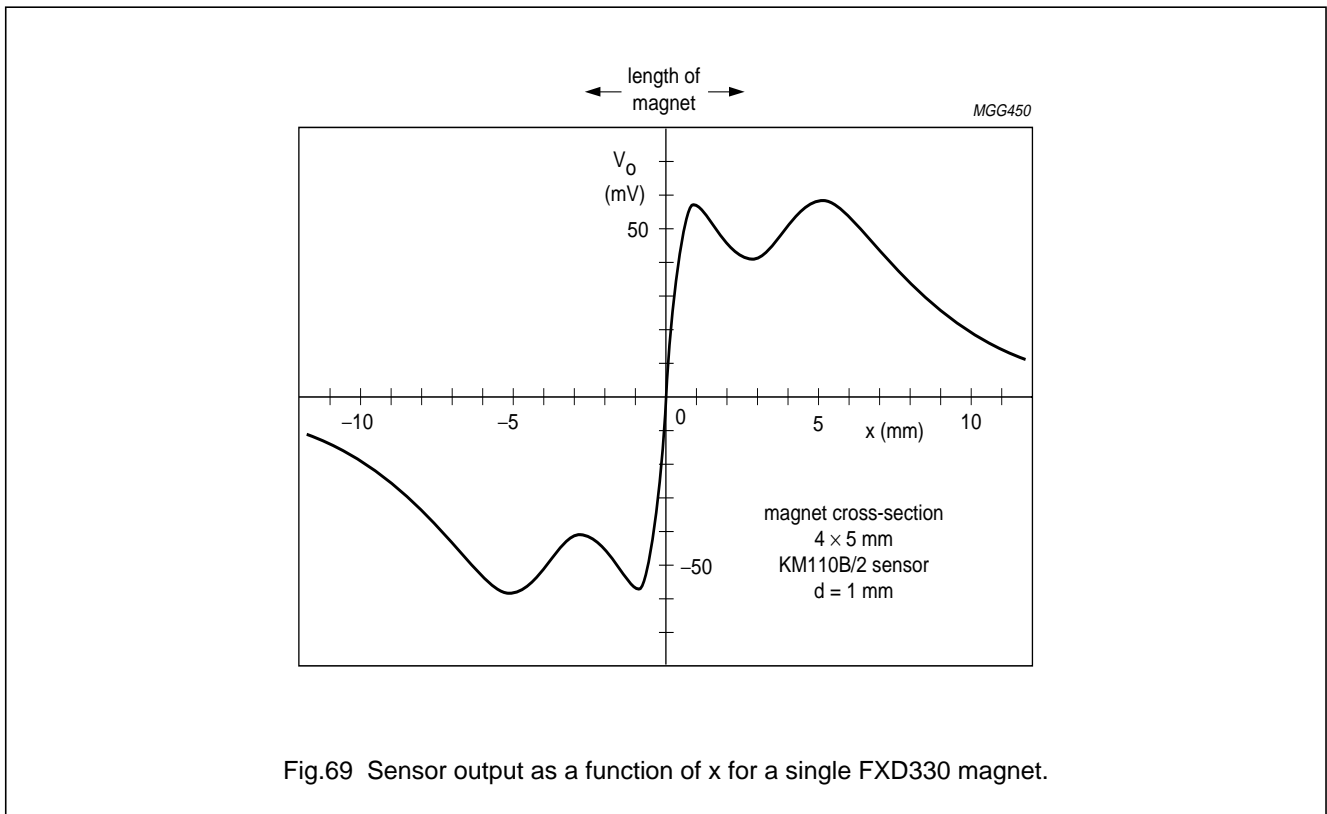

Fig.69 Sensor output as a function of x for a single FXD330 magnet.

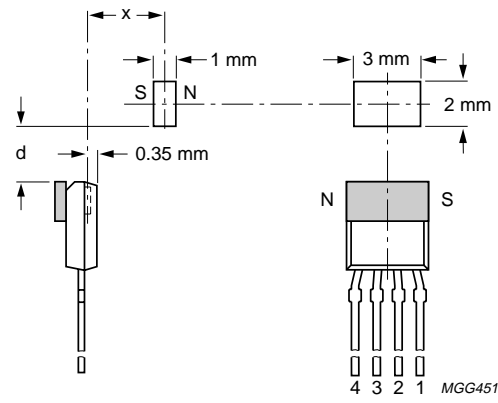

Fig.70 Sensor KM110B/2 perpendicular to magnet field using RES190 magnet.

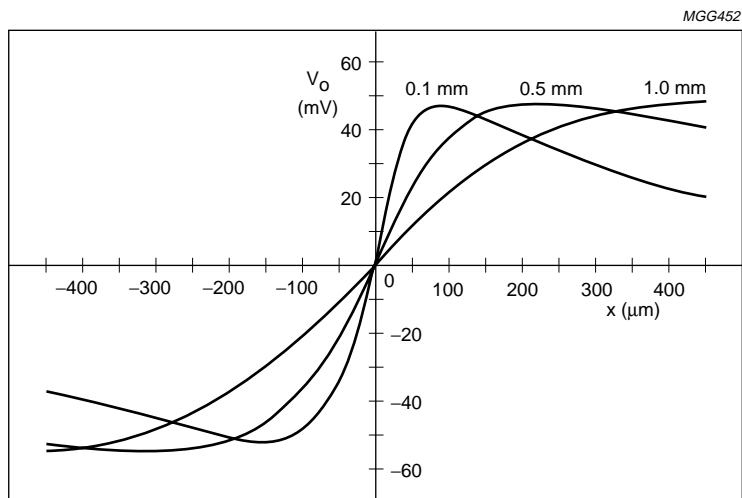

Fig.71 Sensor output as a function of displacement using RES190 magnet.

Magnetic field sensors

General

Reference set-ups

The following are two common set-ups (Fig.72 and Fig.73) that could be used for linear position measurement in real-life applications, together with typical response curves.

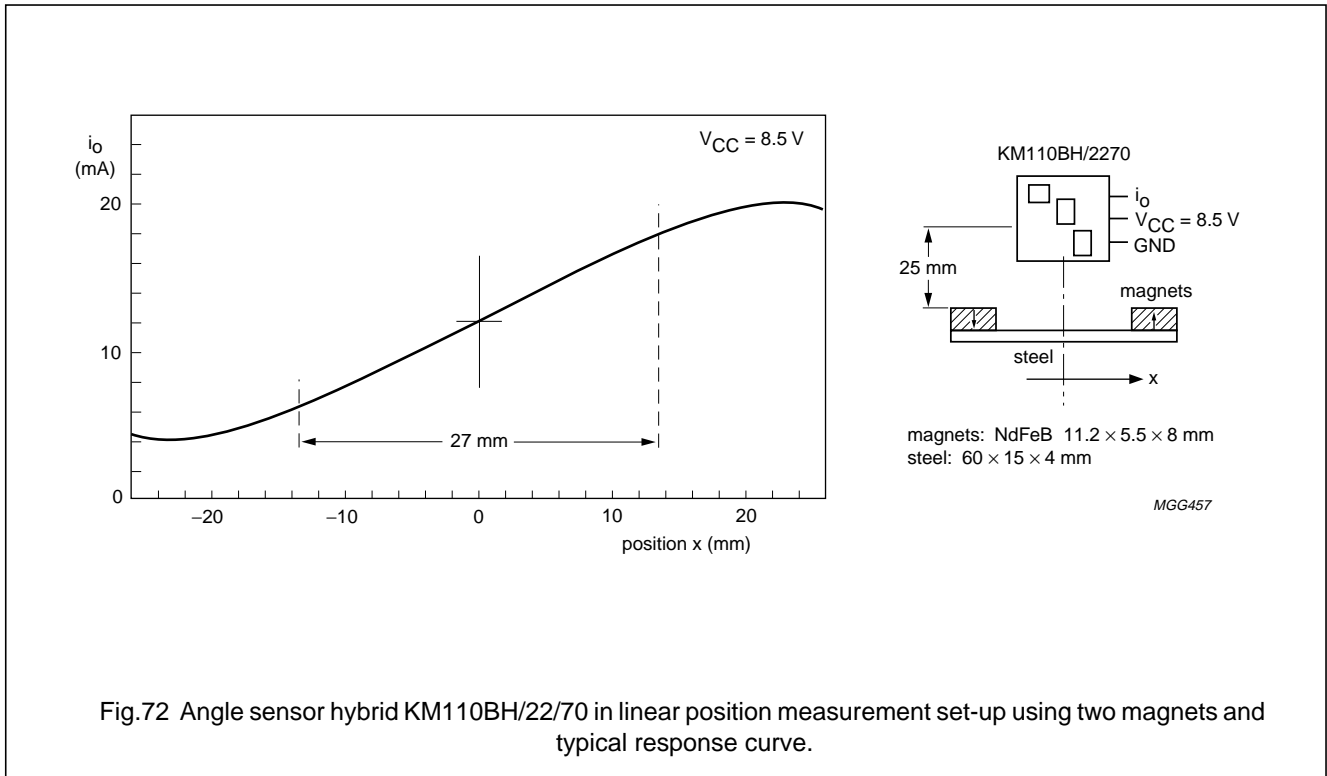

Fig.72 Angle sensor hybrid KM110BH/22/70 in linear position measurement set-up using two magnets and typical response curve.

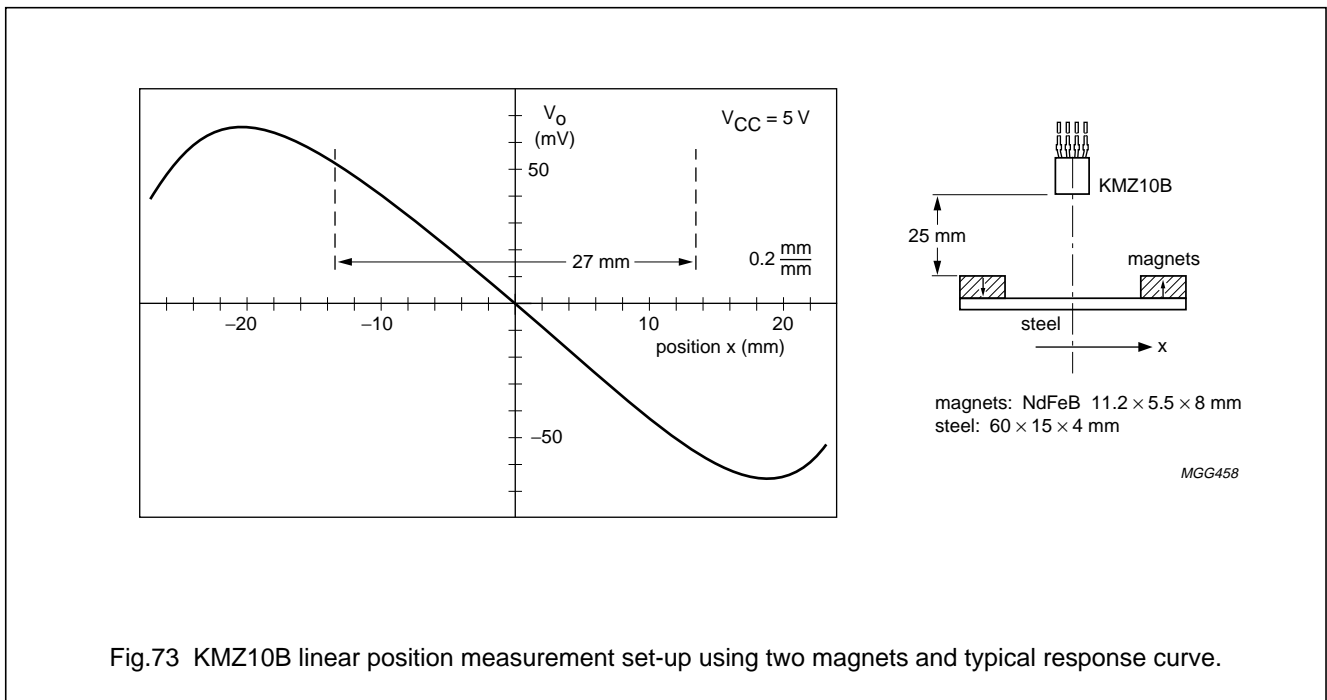

Fig.73 KMZ10B linear position measurement set-up using two magnets and typical response curve.