

**APPLICATION NOTE**

**Electronic Compass Design  
using KMZ51 and KMZ52**

**AN00022**



**Abstract**

*The KMZ51 and KMZ52 from Philips Semiconductors are magnetic field sensors, dedicated to compass applications. Both sensors rely on the magnetoresistive effect and provide the required sensitivity and linearity to measure the weak magnetic field of the earth. While the KMZ51 is a single axis field sensor, the KMZ52 comprises a two-dimensional field sensor, as it is required for a compass, within one package. Both devices are equipped with integrated set/reset and compensation coils. These coils allow to apply the flipping technique for offset cancellation and the electro-magnetic feedback technique for elimination of the sensitivity drift with temperature.*

*Besides the sensor elements, a signal conditioning unit and a direction determination unit are required to build up an electronic compass. The main functions of the signal conditioning unit are amplification of the sensor signals and offset compensation. For high resolution systems, also the temperature drift of sensitivity should be compensated. Both compensation techniques can be implemented simply by controlling the integrated set/reset and compensation coils of the KMZ51/KMZ52. In the direction determination unit, the azimuth is derived as the desired compass output quantity.*

*The given paper shows how to realize signal conditioning and direction determination in conjunction with KMZ51 or KMZ52. Also calibration techniques with respect to interference fields, declination and tilt are pointed out. Finally, system accuracy is covered and examples for complete compass systems are given.*

**APPLICATION NOTE**

**Electronic Compass Design using  
KMZ51 and KMZ52**

**AN00022**

**Author:**

**Thomas Stork  
Philips Semiconductors  
Systems Laboratory Hamburg,  
Germany**

**Keywords**

Earth's magnetic field  
Magnetoresistive sensors  
8-segment compass  
High resolution compass

**Number of pages: 38**

**Date: 00-03-30**

## **SUMMARY**

This paper describes how to realize electronic compass systems using the magnetoresistive sensors KMZ51 and KMZ52 from Philips Semiconductors. Therefore, firstly an introduction to the characteristics of the earth's magnetic field is given. In the following, the main building blocks of an electronic compass are shown, which are two sensor elements for measuring the x- and y-components of the earth field in the horizontal plane, a signal conditioning unit and a direction determination unit.

To provide an understanding of the sensor elements, the magnetoresistive effect and the optimization of the sensor characteristic by using barber pole structures are described briefly. Also the special features of the KMZ5x products, such as set/reset and compensation coils are pointed out. The signal conditioning unit's basic function is to amplify the sensor output voltages, in order to provide reasonable input signals for the following direction determination unit. Beyond that, offset elimination is an essential task. For high precision systems, also sensitivity shifts due to temperature variations should be compensated. Practical methods to fulfill all these tasks either in hardware or software are given. The direction determination unit is the building block for deriving the azimuth as the desired compass output quantity. The azimuth is the angle between magnetic north and the heading direction. For high resolution compass systems, this has to be done mathematically by applying the arcus tangens function to the ratio of the two sensor signals. It is shown, how to implement this function as software. Without this calculation, a more simple 8-segment compass can be realized, which only indicates the nearest cardinal or intermediate point (N, NE, ...).

Besides realization of the basic compass functions, this paper also covers the calibration of electronic compasses against external error sources like magnetic interference fields, deviation between true and magnetic north and tilt. Finally, determination of system accuracy and examples for complete compass systems are given.

**CONTENT**

<b>1. INTRODUCTION</b> .....	<b>7</b>
<b>2. EARTH'S MAGNETIC FIELD</b> .....	<b>8</b>
<b>3. BUILDING BLOCKS OF AN ELECTRONIC COMPASS</b> .....	<b>10</b>
<b>4. MAGNETORESISTIVE (MR) SENSORS FOR COMPASS APPLICATIONS</b> .....	<b>12</b>
<b>4.1 The Magnetoresistive Sensor Element</b> .....	<b>12</b>
4.1.1 The Magnetoresistive Effect .....	12
4.1.2 Optimization of Sensor Characteristic using Barber Pole Structures .....	13
4.1.3 Bridge Configuration .....	13
<b>4.2 Set/Reset and Compensation Coils</b> .....	<b>14</b>
<b>4.3 Philips MR Sensors for Compass Systems</b> .....	<b>15</b>
<b>5. SIGNAL CONDITIONING UNIT (SCU)</b> .....	<b>16</b>
<b>5.1 Requirements</b> .....	<b>16</b>
<b>5.2 Offset Compensation</b> .....	<b>17</b>
<b>5.3 Sensitivity Difference (<math>\Delta S</math>) Compensation</b> .....	<b>19</b>
<b>5.4 Non-orthogonality compensation</b> .....	<b>20</b>
<b>5.5 Circuit Design</b> .....	<b>21</b>
5.5.1 Supply voltage considerations .....	21
5.5.2 Flipping generator (block1) .....	22
5.5.3 Pre-amplifier (block 2).....	23
5.5.4 Offset compensation (block 3) .....	23
5.5.5 Synchronous rectifier (block 4) .....	23
5.5.6 Integral controller (block 5) .....	23
5.5.7 Compensation coil driver (block 6).....	23
5.5.8 SCU without electro-magnetic feedback.....	24
5.5.9 SCU with Microcontroller .....	24
<b>6. DIRECTION DETERMINATION UNIT (DDU)</b> .....	<b>25</b>
<b>6.1 8-Segment Compass</b> .....	<b>25</b>
<b>6.2 High Resolution Compass</b> .....	<b>26</b>
<b>7. INTERFERENCE FIELD CALIBRATION</b> .....	<b>27</b>
<b>8. TRUE NORTH CALIBRATION</b> .....	<b>30</b>
<b>9. TILT COMPENSATION</b> .....	<b>31</b>
<b>10. SYSTEM ACCURACY</b> .....	<b>34</b>
<b>11. APPLICATION EXAMPLES</b> .....	<b>35</b>
<b>12. REFERENCES</b> .....	<b>37</b>
<b>APPENDIX 1 List of abbreviations</b> .....	<b>38</b>
<b>APPENDIX 2 Unit conversions</b> .....	<b>38</b>

**LIST OF FIGURES**

Figure 1	Earth's magnetic field .....	8
Figure 2	Earth field vector .....	9
Figure 3	Functional block diagram of an electronic compass .....	10
Figure 4	The magnetoresistive effect in permalloy .....	12
Figure 5	a) R-H characteristic of a standard sensor, b) R-H characteristic of barber pole sensors .....	13
Figure 6	Barber pole sensor .....	13
Figure 7	Bridge configuration of barber pole sensors .....	14
Figure 8	Fields generated by set/reset and compensation coil.....	14
Figure 9	Simplified circuit diagram of KMZ 51 .....	15
Figure 10	Effect of flipping on sensor characteristic .....	17
Figure 11	Block diagram of flipping circuit .....	17
Figure 12	Timing diagram for flipping circuit .....	18
Figure 13	Typical MR sensor output characteristic (KMZ10).....	19
Figure 14	Block diagram of flipping and electro-magnetic compensation circuit.....	20
Figure 15	Signal conditioning circuit for one sensor .....	21
Figure 16	Flip circuit with active current limiting.....	22
Figure 17	Signal conditioning circuit with microcontroller .....	24
Figure 18	Direction determination for 8-segment compass .....	25
Figure 19	Circuit for 8-segment compass .....	25
Figure 20	Typical test diagrams showing hard iron and soft iron effects.....	27
Figure 21	Principle of bidirectional calibration.....	28
Figure 22	Tilt error.....	31
Figure 23	Tilt error magnitudes .....	32
Figure 24	Definition of pitch and roll.....	32
Figure 25	Electronically gimballed compass.....	33
Figure 26	Analog 8-segment compass .....	35
Figure 27	Analog high resolution compass.....	35
Figure 28	8-segment compass with microcontroller .....	36
Figure 29	High-end compass with microcontroller .....	36

## **1. INTRODUCTION**

The magnetic compass is a crucial navigation tool in many areas, even in times of the global positioning system (GPS). Replacing the “old” magnetic needle compass or the gyrocompass by an electronic solution offers advantages like having a solid-state component without moving parts and the ease of interfacing with other electronic systems.

For the magnetic field sensors within a compass system, the magnetoresistive (MR) technology is the preferable solution. Compared to flux-gate sensors, which could be found in most electronic compasses until now, the MR technology offers a much more cost effective solution, as it requires no coils to be wound and can be fabricated in an IC-like process. Due to their higher sensitivity, MR sensors are also superior to Hall elements in this application field.

The intention of this paper is to give a general introduction of electronic compass design with MR sensors and also to give detailed realization hints. Therefore, the basic characteristics of the earth’s magnetic field are explained and an overview of the building blocks of an electronic compass is given. Following a description of Philips’ magnetoresistive sensors for compass applications, the design of each building block is covered in detail. Here, both hardware and software realisations are shown. Further sections are dedicated to special items like interference field calibration, true north calibration, tilt compensation and system accuracy. Finally, examples for complete compass systems are given, consisting of previously described building blocks.

## 2. EARTH'S MAGNETIC FIELD

The magnetic field of the earth is the physical quantity to be evaluated by a compass. Thus, an understanding of its basic properties is required, when designing a compass. Figure 1 gives an illustration of the field shape.

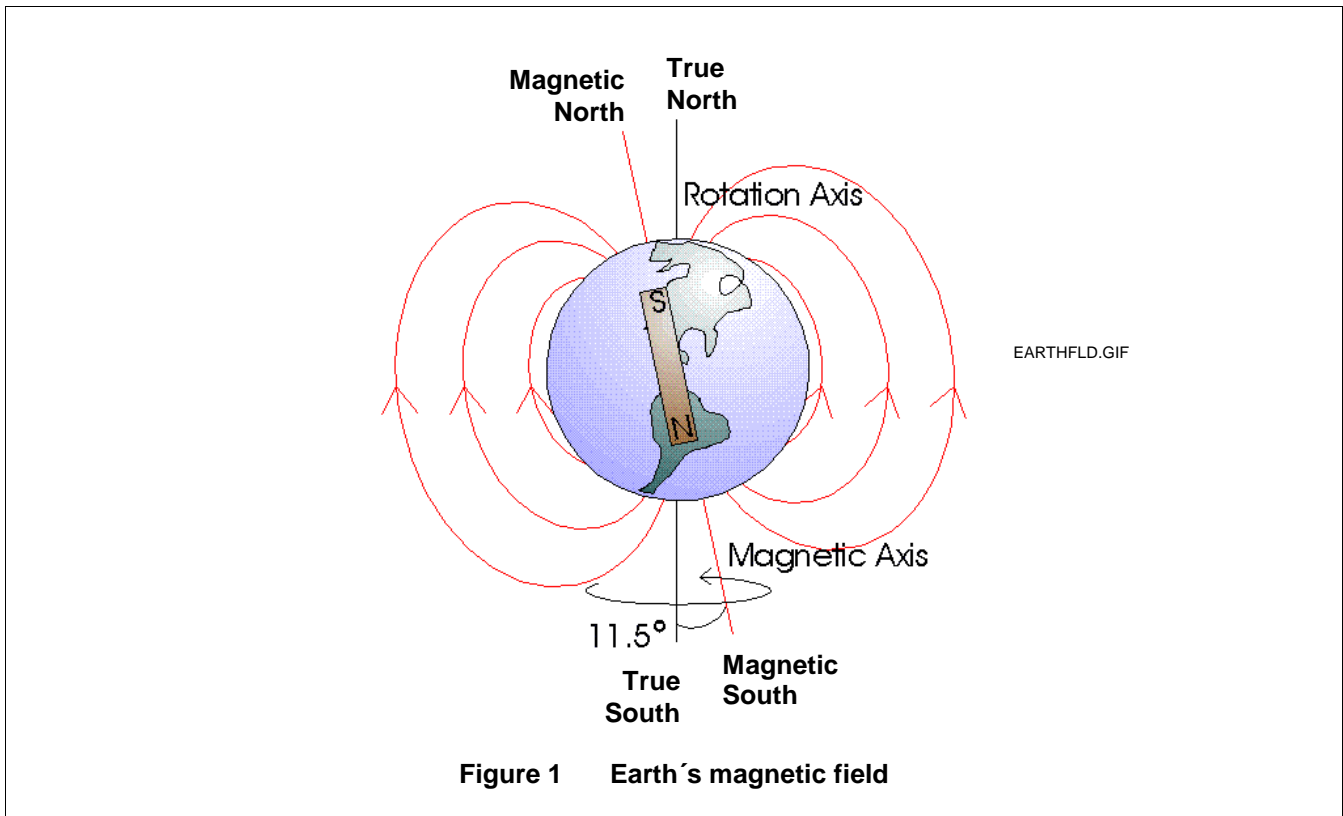

The magnetic field strength on the earth varies with location and covers the range from about 20 to 50 A/m. An understanding of the earth's field shape can be gained, if it is assumed to be generated by a bar magnet within the earth, as pointed out in Figure 1. The magnetic field lines point from the earth's south pole to its north pole. Fig. 1 indicates, that this is opposite to the physical convention for the poles of a bar magnet (the background is a historical one, in that a bar magnet's north pole has been defined as that pole, that points towards north in the earth's magnetic field). The field lines are perpendicular to the earth surface at the poles and parallel at the equator. Thus, the earth field points downwards in the northern hemisphere and upwards in the southern hemisphere. An important fact is, that the magnetic poles do not coincide with the geographical poles, which are defined by the earth's axis of rotation. The angle between the magnetic and the rotation axis is about 11.5°. As a consequence, the magnetic field lines do not exactly point to geographic or "true" north.

Figure 2 gives a 3-D representation of the earth field vector  $\mathbf{H}_e$  at some point on the earth. This illustration allows to define the quantities, which are of importance for a compass. Here, the x- and y-coordinates are parallel to the earth's surface, whereas the z-coordinate points vertically downwards.

- **Azimuth  $\alpha$**

The angle between magnetic north and the heading direction. Magnetic north is the direction of  $H_{eh}$ , the earth's field component perpendicular to gravity. Throughout this paper,  $H_{eh}$  will be referred to as "horizontal" component of the earth's field. Figure 2 shows, that:

$$\alpha = \arctan \frac{H_{ey}}{H_{ex}} \quad (1)$$



The azimuth is the reading quantity of a compass. Throughout this paper,  $\alpha$  is counted clockwise from magnetic north, i.e. north is  $360^\circ$  or  $0^\circ$ , east is  $90^\circ$ , south is  $180^\circ$ , west is  $270^\circ$ .

- Inclination or dip  $\delta$**   
 The angle between the earth's field vector and the horizontal plane. As already pointed out, the inclination varies with the actual location on earth, being zero at the equator and approaching  $\pm 90^\circ$  near the poles. If a compass is tilt, then inclination has to be considered, as explained in section 9.
- Declination  $\lambda$**   
 The angle between geographic or true north and magnetic north. Declination is dependent on the actual position on earth. It also has a long term drift. Declination can be to the east or to the west and can reach values of about  $\pm 25^\circ$ . The azimuth measured by a compass has to be corrected by the declination in order to find the heading direction with respect to geographic north. This is pointed out in section 8.

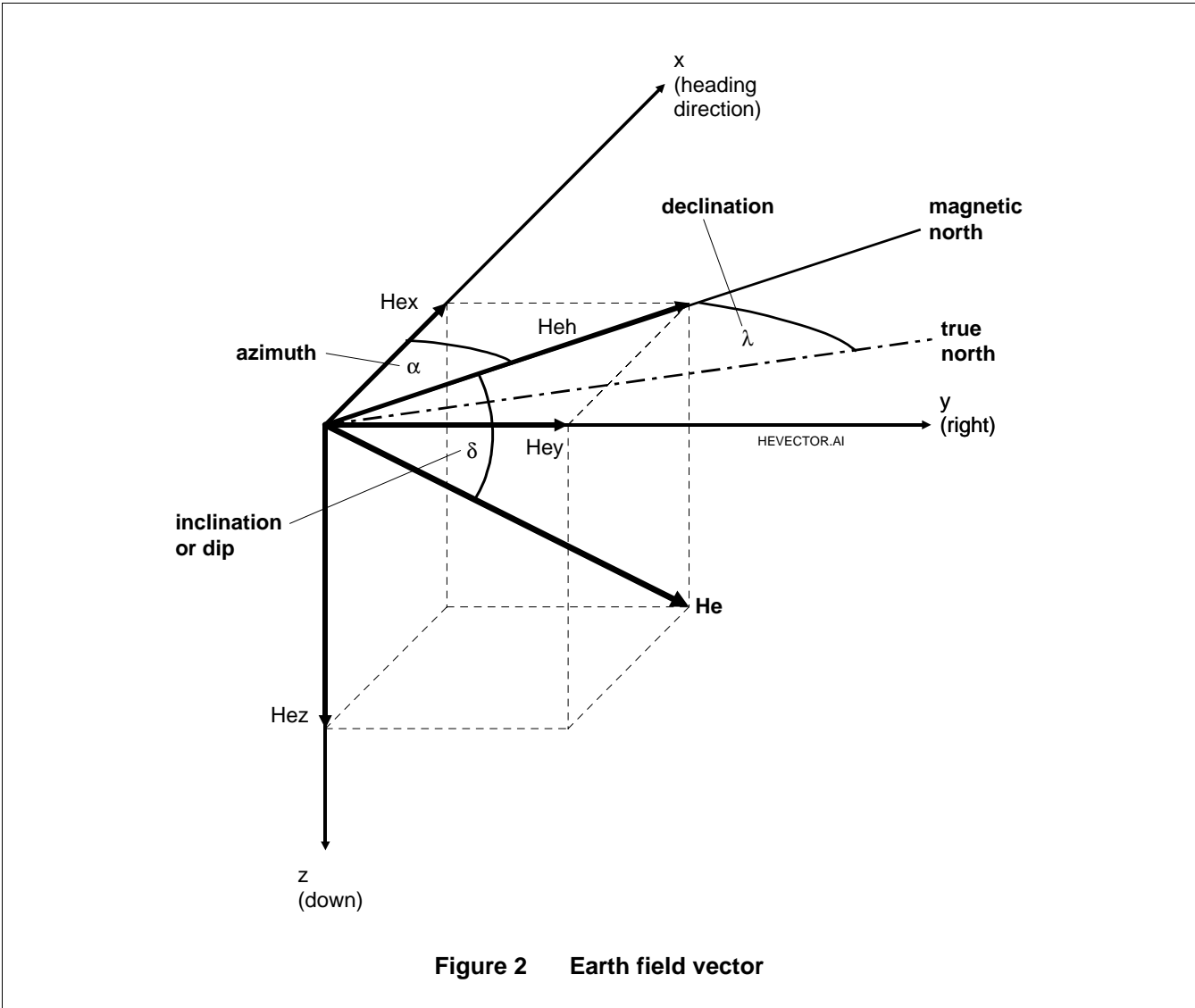

**Figure 2 Earth field vector**

**3. BUILDING BLOCKS OF AN ELECTRONIC COMPASS**

Figure 3 shows a functional block diagram of an electronic compass. This is a minimum set-up, i.e. these elements are principally required for any electronic compass. The functional blocks – except the field sensor – can be realized either as hardware or as software. In the following, the functions of each block are summarized. A detailed description of each block together with examples for realization are given in the following sections.

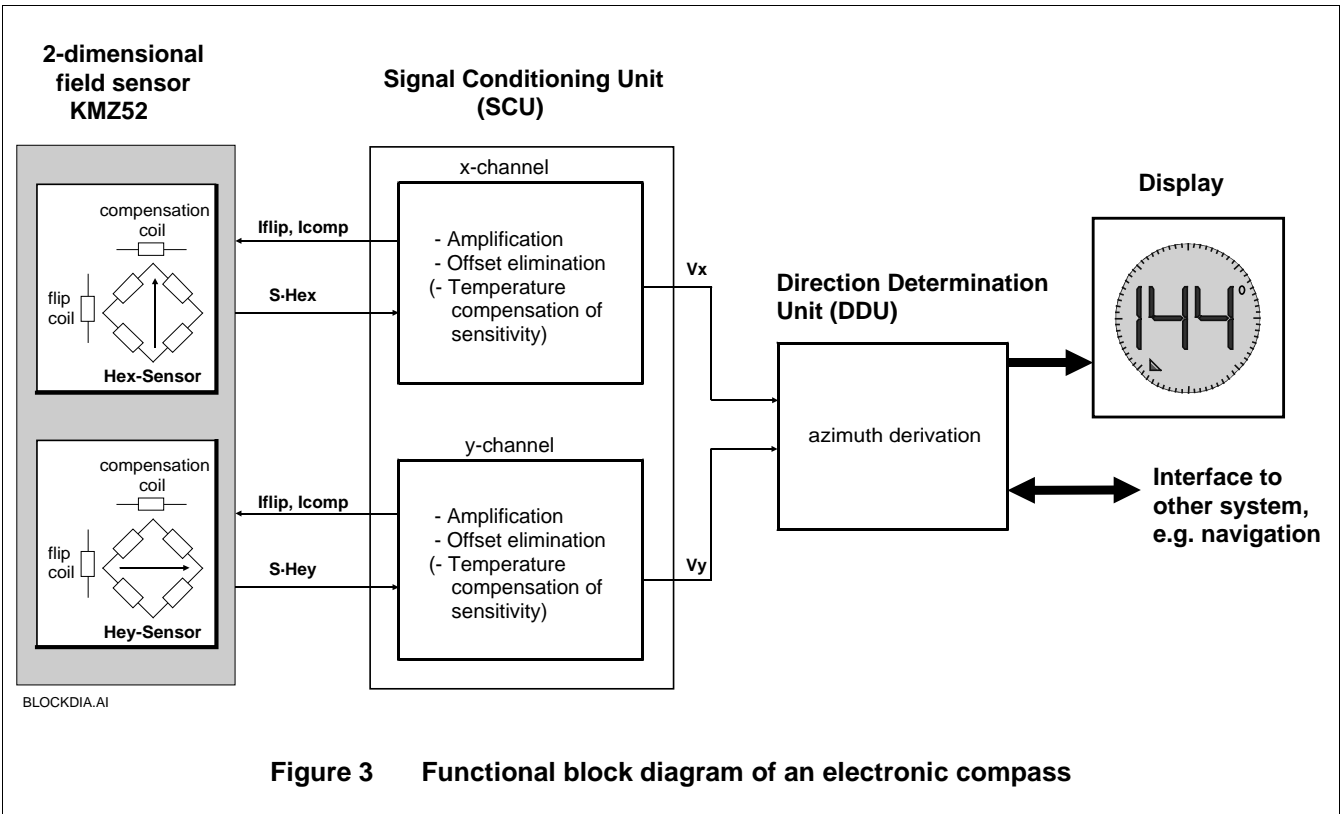

**Figure 3 Functional block diagram of an electronic compass**

• **Magnetic field sensors**

As already pointed out, the task of a compass is to measure the azimuth  $\alpha$ , i.e. the angle between north and heading direction, as defined by equation (1). Therefore, the strengths of two horizontal earth field components have to be measured: one in heading direction (Hex) and one sideways (Hey). This requires two magnetic field sensors, both aligned parallel to the earth’s surface, but rotated by 90 degrees with respect to each other.

Philips’ magnetoresistive sensor technology is an optimum choice for measuring weak magnetic fields like the earth’s field. The KMZ52 is a sensor device, which is perfectly matched to this application, as it comprises two extremely sensitive field sensors in the required configuration in one SO16 package. Furthermore, the KMZ52 comprises for each of its sensors a set/reset coil needed for offset elimination and a coil for the compensation of sensitivity temperature drift. Thus, the KMZ52 makes any external coils obsolete, which are required when using other sensor products. Section 4 describes Philips’ magnetoresistive sensor technology and introduces those products, which are dedicated to compass applications.

• **Signal conditioning unit (SCU)**

The purpose of this block is to deliver output voltages proportional to the field strengths Hex and Hey respectively. Therefore, the signals delivered by the magnetic field sensors have to be amplified. Also offsets have to be eliminated. Beyond that, the amplification of one SCU channel should be trimable in order to allow

the compensation of sensitivity differences between the x- and the y- field sensor. Optional features for high performance systems are temperature compensation of sensitivity and compensation of the error due to non-orthogonality between the sensors. To fulfill these tasks, the signal conditioning unit has to influence the sensors by controlling their set/reset and compensation coils. The SCU is the most crucial part concerning system accuracy. Section 5 gives a detailed description of the required functions within the signal conditioning unit as well as solutions in hardware and software.

- **Direction determination unit (DDU)**

The function of this block is to derive the desired azimuth information from the measured field strengths  $H_{ey}$  and  $H_{ex}$ . For high resolution compasses, this can be done by evaluating the arctan function of equation (1) with a microcontroller. With less effort, a simple 8-segment compass can be built up, which only provides major direction indication (N, NE, E, etc.). Section 6 gives some more hints on this.

- **Display / Interface**

Finally, the measured azimuth has to be indicated to the user by a display and/or has to be delivered to another electronic system. The latter could be the navigation system of a car, which uses the compass information for "dead reckoning", i.e. for determination of the relative position during time intervals, where GPS signals cannot be received (e.g. when driving between high buildings). Section 11 shows complete application examples, which give some hints on display driving and interfacing.

- **Further features**

Figure 3 shows those elements, which are required for any electronic compass. However, depending on the actual application, further features may be demanded. The most important of these are:

- Interference field calibration  
In most practical cases, the earth field to be measured is superimposed by other magnetic fields, which would cause a significant measurement error, if not compensated. Section 7 gives an introduction on this topic.
- True north calibration  
As pointed out in section 2, there is a deviation between the magnetic north direction (measured by the compass) and true or geographic north. Section 8 gives more information on this item.
- Tilt compensation  
Equation (1) only yields the correct azimuth, if  $H_{ex}$  and  $H_{ey}$  are the earth field components in the horizontal plane. Thus, the basic compass sketched in Figure 3 must be held exactly horizontal to work properly. Section 9 discusses the error that occurs, when a compass is tilt and shows how to compensate this error electronically.

## 4. MAGNETORESISTIVE (MR) SENSORS FOR COMPASS APPLICATIONS

The intention of this section is to describe the basic principles of magnetoresistive sensors, which a compass designer should know. A more detailed description of the magnetoresistive effect can be found in [3].

### 4.1 The Magnetoresistive Sensor Element

#### 4.1.1 The Magnetoresistive Effect

Magnetoresistive (MR) sensors make use of the magnetoresistive effect, the property of a current carrying magnetic material to change its resistivity in the presence of an external magnetic field. Figure 4 shows a strip of ferromagnetic material, called permalloy (19% Fe, 81% Ni).

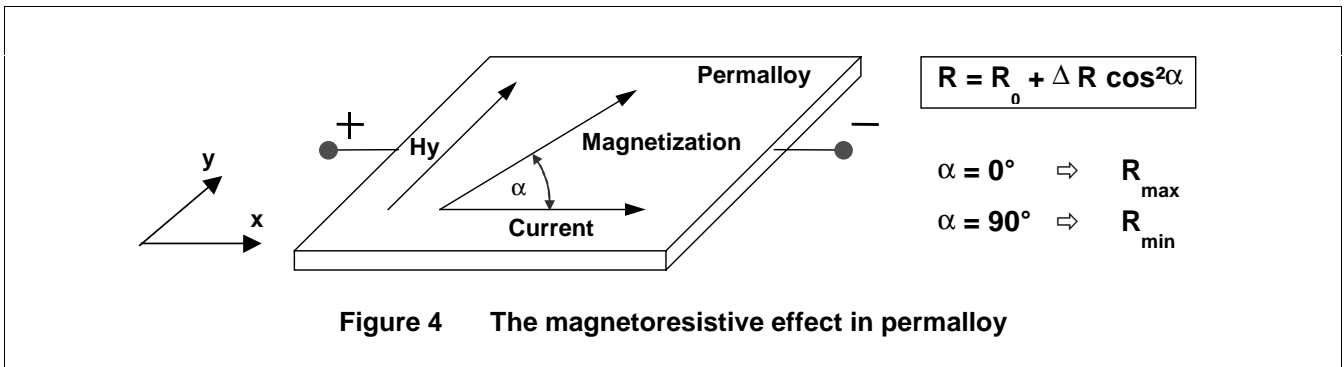

During deposition of the permalloy strip, a strong external magnetic field is applied parallel to the strip axis. By doing this, a preferred magnetization direction is defined within the strip. In absence of any external magnetic field, the magnetization always points into this direction. In Figure 4, this is assumed to be the x-direction, which is also the direction of current flow. An MR sensor now relies on two basic effects:

- The strip resistance  $R$  depends on the angle  $\alpha$  between the direction of the current and the direction of the magnetization.
- The direction of magnetization and therefore  $\alpha$  can be influenced by an external magnetic field  $H_y$ , where  $H_y$  is parallel to the strip plane and perpendicular to the preferred direction.

When no external magnetic field is present, the permalloy has an internal magnetization vector parallel to the preferred direction, i.e.  $\alpha = 0$ . In this case, the strip resistance  $R$  has its maximum value  $R_{\max}$ . If now an external magnetic field  $H_y$  is applied, the internal magnetization vector of the permalloy will rotate around an angle  $\alpha$ . At high field strengths, the magnetization tends to align itself parallel to  $H_y$  and the rotation angle  $\alpha$  approaches  $90^\circ$ . In this case, the resistance reaches its minimum value  $R_{\min}$ . The equation next to Figure 4 gives the functional dependence between  $R$  and  $\alpha$ , where  $R_0 = R_{\min}$  and  $\Delta R = (R_{\max} - R_{\min})$ . Finally, the function of  $R$  versus  $H_y$  is as follows:

$$R = R_0 + \Delta R \cdot \left( 1 - \left( \frac{H_y}{H_0} \right)^2 \right) \quad (2)$$

Figure 5a shows a diagram for equation (2).  $H_0$  is a parameter, which depends on material and geometry of the strip. Equation (2) is defined for field strength magnitudes of  $H_y \leq H_0$ . For  $H_y > H_0$ ,  $R$  equals  $R_0$ .  $R_0$  and  $\Delta R$  are also material parameters. For permalloy,  $\Delta R$  is in the range of 2 to 3% of  $R_0$ .

**4.1.2 Optimization of Sensor Characteristic using Barber Pole Structures**

Figure 5a illustrates the sensor characteristic according to (2). For small magnitudes of  $H_y$ , the sensitivity is very low and non-linear. Furthermore, this characteristic does not allow to detect, whether  $H_y$  is positive or negative. Therefore, the basic sensor structure of Figure 4 has to be improved for compass applications.

The desired sensor improvements can be achieved by depositing aluminium stripes (called barber poles) on top of the permalloy strip at an angle of  $45^\circ$  to the strip axis. Figure 6 shows the principle. As aluminium has a much higher conductivity than permalloy, the effect of the barber pole is to rotate the current direction by  $45^\circ$ , effectively changing the angle between the magnetisation and the electrical current from  $\alpha$  to  $(\alpha - 45^\circ)$ . Graph b) in Figure 5 shows the impact on the sensor characteristic due to the barber pole structure. For weak fields like the earth's field, the sensitivity now is significantly higher, the characteristic is linearized and allows to detect the sign of  $H_y$ .

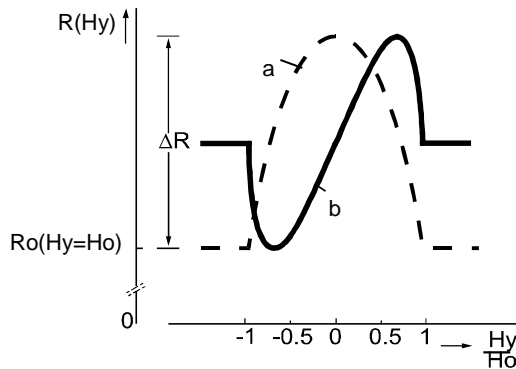

**Figure 5 a) R-H characteristic of a standard sensor,  
b) R-H characteristic of barber pole sensors**

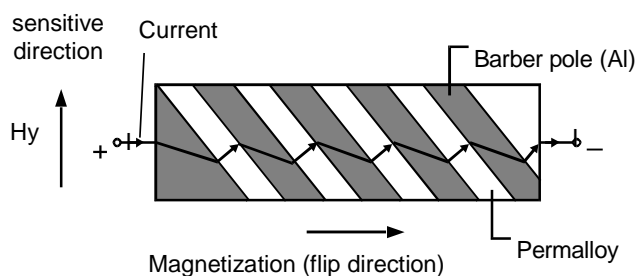
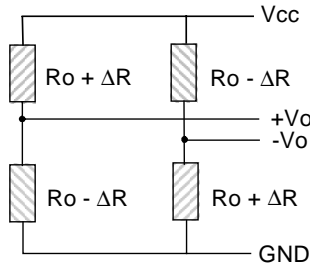

**Figure 6 Barber pole sensor**

**4.1.3 Bridge Configuration**

Practically, it is advantageous to build up a sensor element as a Wheatstone bridge, consisting of four magnetoresistive strips, as shown in Figure 7. For compass sensors, barber pole structures are used, where one diagonal pair is orientated at  $+45^\circ$  to the strip axis, while the other pair is orientated at  $-45^\circ$ . Thus, the resistance variation  $\Delta R$  due to a magnetic field is converted linearly into a variation of the differential output

voltage  $\Delta V = +V_o - (-V_o)$ . Moreover, the inherent temperature coefficients of the four bridge resistances are mutually compensated.



**Figure 7 Bridge configuration of barber pole sensors**

**4.2 Set/Reset and Compensation Coils**

MR sensors are by nature bi-stable, i.e. the direction of their internal magnetization can be inverted or “flipped”. This can be achieved by a magnetic field of sufficient strength, if that field is applied parallel to the magnetization, but having opposite direction (refer to Figure 8). Flipping causes an inversion of the sensor characteristic, such that the sensor output voltage changes polarity.

MR sensors can be stabilized against unwanted flipping by applying an auxiliary magnetic field parallel to the flipping axis. This field should be pulsed, as a permanent field would decrease the sensitivity. When measuring weak fields, it is even desired to invert or “flip” the sensor characteristic repetitively. This allows to compensate the sensor’s offset in a way comparable to the chopping technique used in the amplification of small electrical signals. A “set/reset” coil near the sensor element is a means to apply the auxiliary field for the flipping.

In high precision compass systems, the sensor must also allow to compensate sensitivity drift with temperature and to compensate interference fields. Both can be done by means of an auxiliary field in the sensitive direction. This can be generated by a “compensation” coil near the sensor element.

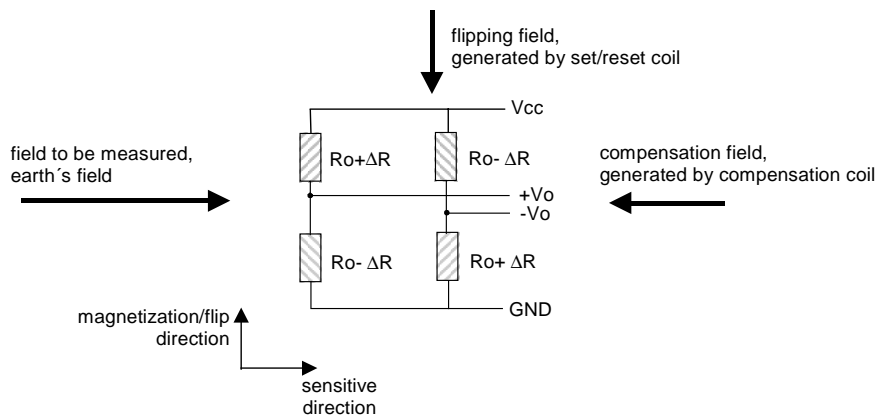

**Figure 8 Fields generated by set/reset and compensation coil**

Philips MR sensors dedicated for compass applications are available with integrated set/reset and compensation coils, saving the additional cost and effort to provide external coils. Furthermore, as integrated

coils can be arranged much closer to the sensor element, they require significantly less current to generate the required field strengths. This reduces expenditure and thus cost at the signal conditioning unit side.

In the signal conditioning section, the techniques of flipping and compensation are described in detail.

**4.3 Philips MR Sensors for Compass Systems**

Philips Semiconductors offers at present two sensor products, dedicated to this application field. Both products employ the previously described barber pole structure with its inherent linearity and high sensitivity.

The primary device is the KMZ52, which comprises all elements of a compass sensor system within one package, i.e. two weak field sensors with 90° displacement, each having a set/reset and a compensation coil (ref. to figure 3). The KMZ51 is a single sensor with set/reset and compensation coils. This can be employed together with a KMZ52 to form a three-dimensional sensor, in order to compensate for tilt, as will be described in section 9. Figure 9 shows a simplified circuit diagram of the KMZ51, showing the MR resistor bridge as well as the set/reset and compensation coils.

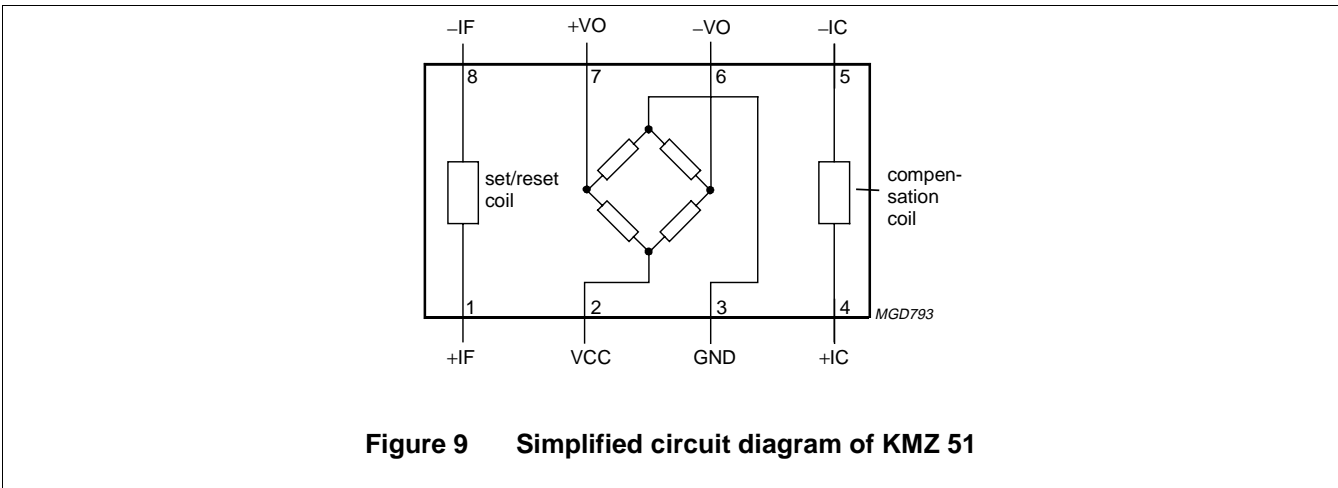

**Figure 9 Simplified circuit diagram of KMZ 51**

**Table 1 Philips MR sensors for compass applications**

	<b>KMZ51</b>	<b>KMZ52</b>	<b>UNIT</b>
<b>1- or 2-dimensional sensor</b>	1-dim.	2-dim.	-
<b>Package</b>	SO 8	SO 16	-
<b>recommended supply voltage</b>	5	5	V
<b>typ. sensitivity</b>	16	16	(mV/V) / (kA/m) <sup>1</sup>
<b>offset voltage</b>	-1.5 ... 1.5	-1.5 ... 1.5	mV/V <sup>2</sup>
<b>Applicable field range</b>	-0.2 ... 0.2	-0.2 ... 0.2	kA/m
<b>Integrated set/reset coils for flipping</b>	yes	yes	-
<b>Integrated compensation coils</b>	yes	yes	-

1 Thus, the sensor delivers 16mV per V supply voltage and per kA/m field strength.  
 2 Thus, the maximum offset voltage is ± 1.5mV per V supply voltage.

## 5. SIGNAL CONDITIONING UNIT (SCU)

### 5.1 Requirements

The SCU consists of two separate “channels” fulfilling the basic task of amplifying the x- and y-field sensor output voltages (refer to Figure 3). Considering a minimum earth field strength in the sensor plane of approximately 15 A/m and a sensor sensitivity of typically 80 mV/(kA/m) (at  $V_{CC} = 5V$ , refer to Table 1), an MR sensor will deliver an amplitude of approximately 1.2 mV, when rotated in that field. Therefore, significant amplification is required in order to provide reasonable voltages for the following direction determination stage.

Depending on the desired system accuracy, the SCU has to fulfil up to three further requirements. These are the elimination of the following error sources:

- **Offset voltages  $V_{ox}$ ,  $V_{oy}$  at the SCU output:**  
These are caused by the offsets of the sensor elements and the connected amplifier. Offset of a sensor element arises due to the tolerances and temperature drift of the four magnetoresistive elements, which are arranged as a Wheatstone bridge. Thus, the sensor output voltage deviates from zero, if no magnetic field is applied.
- **Sensitivity difference  $\Delta S$  between x- and y- channel of the SCU:**  
This is due to tolerance and temperature drift of sensor sensitivities and the following amplification.
- **Non-orthogonality  $\beta$  of sensors:**  
Due to mounting tolerances, the real angular displacement between the sensors deviates from the desired 90° by an angle  $\beta$ .

Equation (3) indicates the effect of these error sources on the azimuth reading. Here it is assumed that the direction determination unit carries out equation (1) by replacing  $H_{ey}$  and  $H_{ex}$  with the respective SCU output voltages  $V_y$  and  $V_x$ . As each output voltage equals the measured earth’s field component times channel sensitivity plus offset, the azimuth reading is:

$$\alpha = \arctan \frac{V_y}{V_x} = \arctan \frac{H_e \cdot (S + \Delta S) \cdot \sin(\alpha + \beta) + V_{oy}}{H_e \cdot S \cdot \cos \alpha + V_{ox}} \quad (3)$$

Equation (3) becomes identical to equation (1), i.e. the real azimuth is derived, if  $V_{ox}$ ,  $V_{oy}$ ,  $\Delta S$  and  $\beta$  are eliminated. The azimuth errors caused by offsets,  $\Delta S$  and  $\beta$  are periodic functions of  $\alpha$ . The amplitudes of these functions, i.e. the maximum azimuth errors, can be assumed as proportional to the magnitude of the respective error source. Table 2 in section 10 states the equations for these azimuth errors together with an indication of their maximum value depending on the respective error source:

- Offset error:  $E_{\text{offset}} \approx 0.8 \text{ }^\circ\%$ ,  
i.e. an offset to amplitude ratio of 1% causes a max. azimuth error of 0.8°.
- Sensitivity difference error:  $E_{\Delta S} \approx 0.3 \text{ }^\circ\%$ ,  
i.e. a  $\Delta S/S$  ratio of 1% causes an error of 0.3°.
- Non-orthogonality error:  $E_{\beta} \approx 1 \text{ }^\circ$ ,  
i.e. a 1° deviation from orthogonality between the sensors causes a max. azimuth error of 1°.

The KMZ52 is specified to have an offset voltage of max.  $\pm 1.5\text{mV/V}$  and an offset drift of max.  $\pm 3\mu\text{V}/(\text{V/K})$  (refer to Table 1). Thus, at the recommended supply of 5V, the max. offset voltage at 25°C is  $\pm 7.5\text{mV}$  and the max. offset drift, e.g. over a temperature range of 100°C, is 1.5mV. Comparing these values with the sensor voltage amplitude of 1.2mV as derived above, it becomes evident, that offset level and even offset temperature drift can be significantly higher than the desired signal. As a consequence, an efficient in-circuit offset compensation is crucial for every compass system, even for “low end” products. Section 5.2 shows techniques to realize this.



To compensate for sensitivity differences  $\Delta S$ , the SCU should allow to trim its output voltages for equal amplitudes when rotated in the earth field. If high accuracy is desired over a wide temperature range, also an automatic compensation of sensitivity temperature drift should be implemented. Section 5.3 shows the realization.

The maximum non-orthogonality specified for the KMZ52 is  $2^\circ$ , causing a maximum azimuth error of  $2^\circ$ . For applications, where this is not sufficient, section 5.4 shows a principle, to correct this error mathematically.

**5.2 Offset Compensation**

A technique called “flipping” can be used here, which allows to eliminate the offset similar to the “chopping” technique used for the amplification of small electrical signals: When the bi-stable sensor is subjected to a reversible magnetic field in its flipping direction, its internal magnetization  $M_x$  and thus its characteristic  $V_o$  vs.  $H_y$  is reversed or “flipped” as shown in Figure 10 (refer also to section 4.2). If the flipping is done repetitively, the desired output voltage will change polarity, thus appearing as amplitude of an ac signal. However the offset voltage does not change polarity, thus appearing as a dc offset of that signal. This allows to compensate the sensor’s offset by filtering the dc component from its flipped output signal. A subsequent rectification then allows to convert the ac signal back to the desired dc sensor signal.

Figure 11 shows the block diagram of a flipping circuit. The flipping is generated by applying alternately positive and negative current pulses to the set/reset coil of the sensor. To avoid loss in sensitivity, the current pulses should be short (only a few  $\mu s$ ). Although the frequency is not critical, some design hints are given later on when coming to practical solutions. After pre-amplification, a high pass filter removes the sensor offset from the flipped output signal. A synchronous rectifier converts the flipped signal to a dc signal, that is now free of offset. A clock signal is required for controlling the flipping source and the rectifier, which must be synchronized with the flipping. Figure 12 shows a timing diagram with the signals of the flipping circuit.

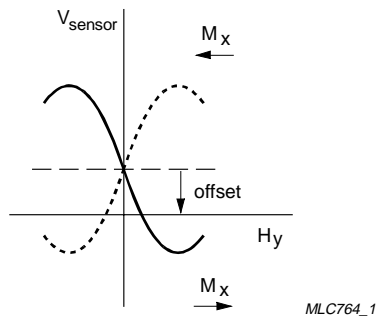

**Figure 10 Effect of flipping on sensor characteristic**

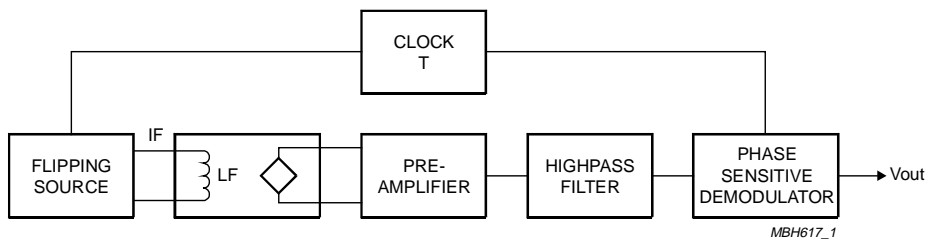

**Figure 11 Block diagram of flipping circuit**

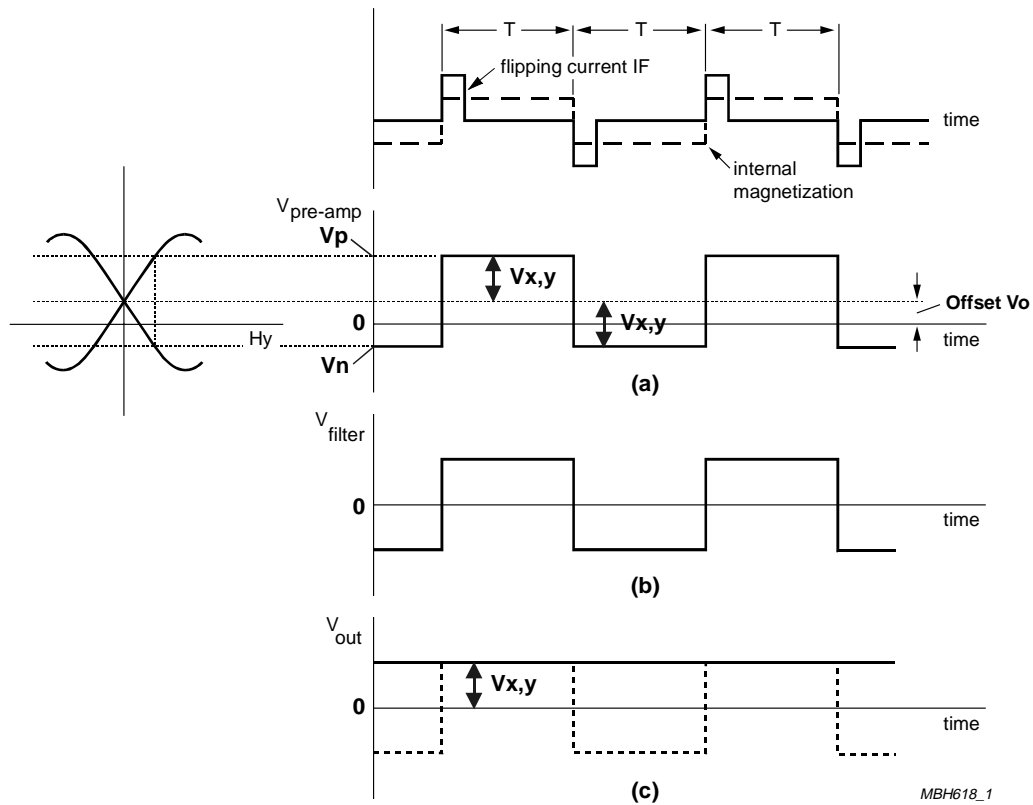

**Figure 12 Timing diagram for flipping circuit**  
**(a) voltage at preamp output; (b) voltage at filter output;**  
**(c) voltage at rectifier output**

The filter and the synchronous rectifier in Figure 11 can be saved, if a microcontroller with A/D converter is available. In that case, the desired output voltages  $V_{x,y}$  can be calculated from the high-level voltage  $V_p$  and the low-level voltage  $V_n$  of the flipped and amplified sensor signal (refer to Figure 12a) as:

$$V_{x,y} = \frac{1}{2} \cdot (V_p - V_n) \quad (4)$$

Assuming that the offset does not vary rapidly with time, the microcontroller load can be reduced by reading  $V_p$  and  $V_n$  only after longer time intervals, e.g. minutes, to calculate and store the actual offset voltage  $V_o$ :

$$V_o = \frac{1}{2} \cdot (V_p + V_n) \quad (5)$$

For azimuth calculation, then only one level of the flipped sensor signal has to be read by the microcontroller, e.g.  $V_p$ :

$$V_{x,y} = V_p - V_o \quad (6)$$

Section 5.4 gives practical circuit examples and design hints for the flipping circuit. A pure hardware solution as well as a realisation using a microcontroller are considered.

**5.3 Sensitivity Difference ( $\Delta S$ ) Compensation**

At a given temperature,  $\Delta S$  can be compensated by adjusting the SCU for equal output voltage swings  $V_{y,pp}$  and  $V_{x,pp}$  during compass rotation. The output voltage swings can be equalized by adjusting the amplification of one SCU channel. An alternative software solution would be to correct one output voltage mathematically: As the ratio  $V_{y,pp}/V_{x,pp}$  equals the ratio of sensitivities  $S_y/S_x=(S+\Delta S)/S$ ,  $V_y$  can be corrected as follows:

$$V_{y,corrected} = V_{y,measured} \cdot \frac{V_{x,pp}}{V_{y,pp}} \quad (7)$$

When determining  $\Delta S$  by measuring SCU output voltage swings, soft iron interference effects have to be avoided carefully, as these would also appear as difference in output voltage swings (refer to section 7).

To maintain high accuracy over temperature, the temperature drift of sensor sensitivity should be compensated during operation. Figure 13 shows the output characteristic  $V_o$  vs.  $H$  of a typical MR sensor element at different temperatures. All these curves indicate, that the sensor output is significantly dependent on temperature except at its zero point: a field strength of zero always causes an output voltage of exactly zero, independent of temperature. Of course this is only true disregarding sensor offset. However, offset can be eliminated perfectly by means of the flipping technique, as described above.

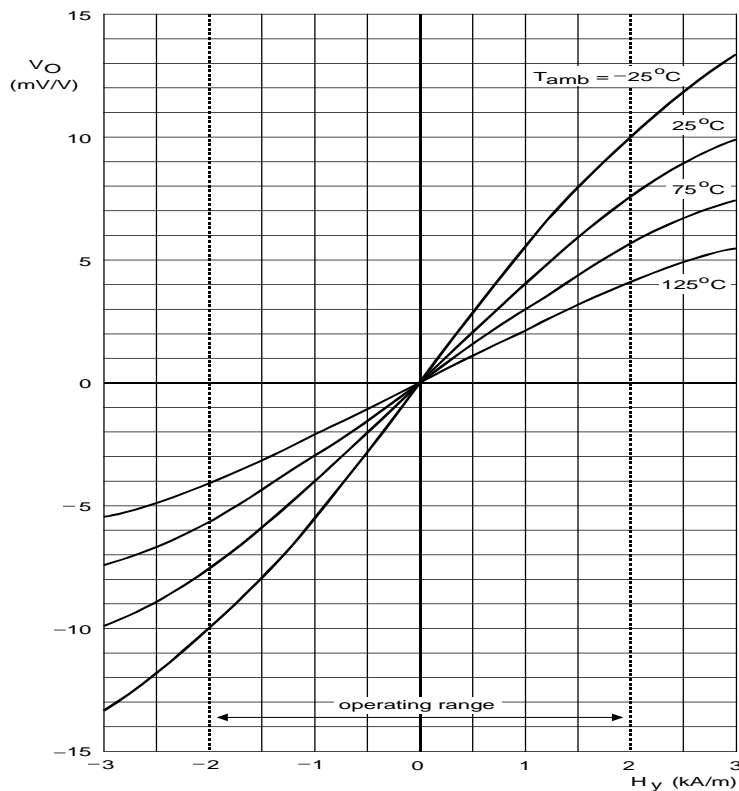
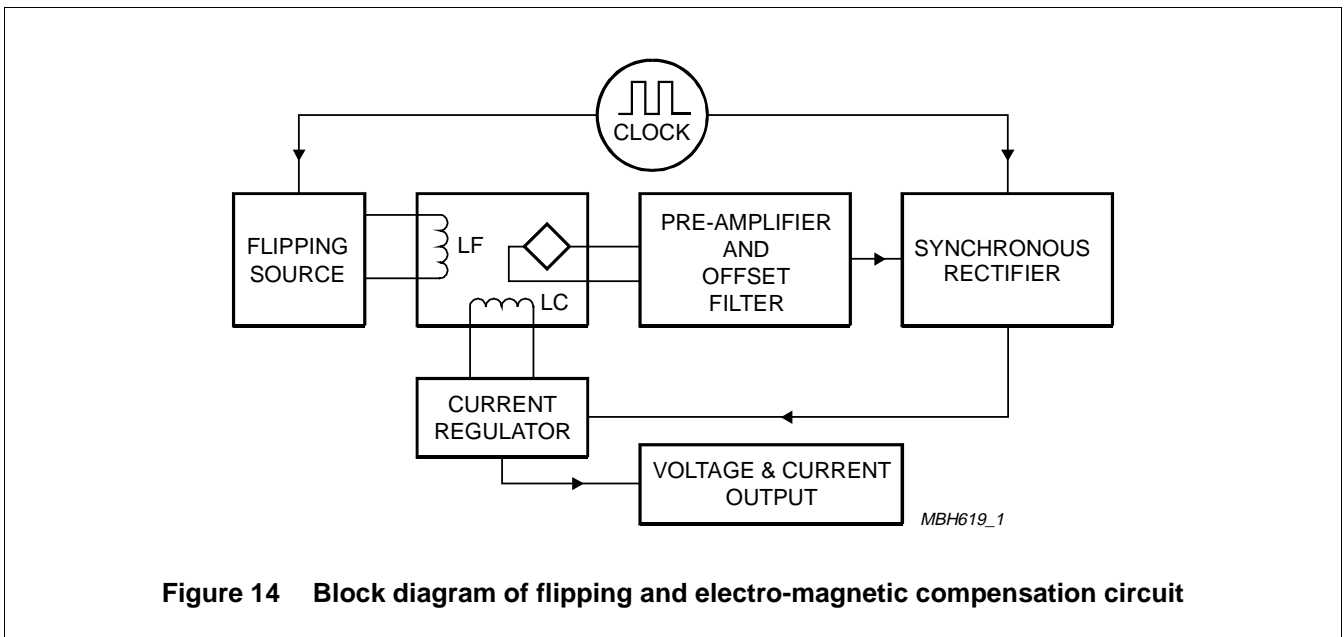

**Figure 13 Typical MR sensor output characteristic (KMZ10)**

Thus, temperature drift can be compensated by operating the sensors at their zero point. Therefore, the earth field component at each sensor has to be compensated by an opposing field of equal strength. If now magnitude and polarity of this compensation field are known, the measurement task is fulfilled, even though the sensor delivers zero output signal. This method is referred to as “electro-magnetic feedback”.

Practically, the compensation field can be generated by supplying a current through an appropriate coil near the sensor. As already pointed out, Philips MR sensors for compass applications come with an integrated compensation coil, allowing to apply the electro-magnetic feedback method without the need for any external coils. Due to the well defined field factor of these integrated compensation coils, there is a well defined proportionality between field strength to be measured and compensation current.

Figure 14 shows a block diagram for an SCU channel employing both flipping and electro-magnetic feedback. The electro-magnetic feedback circuit is a closed-loop controller, in which a current regulator feeds the compensation coil in order to keep the sensor output voltage at zero. In order to achieve a sensor output voltage of exactly zero, a current regulator with integral characteristic is required. The measured field strength can be represented as voltage, proportional to the compensation current.



**Figure 14 Block diagram of flipping and electro-magnetic compensation circuit**

**5.4 Non-orthogonality compensation**

Up to this point it has been assumed, that the two magnetic field sensors are displaced at an angle of exactly 90°. However, in practice the displacement will deviate by an angle β from the desired orthogonality due to mounting tolerances. This deviation causes an error in compass reading, which is a periodic function of the azimuth (see Table 2 in section 10). The maximum error is approximately equal to the non-orthogonality β. Thus, for the KMZ52 with a specified max. non-orthogonality of 2°, the max. azimuth error is also 2°.

If a higher accuracy is desired, β should be compensated. If the compass is rotated with respect to the earth’s field, then the phase shift between V<sub>x</sub> and V<sub>y</sub> is 90°±β. Having determined β, the error can be eliminated mathematically:

Assuming, that the SCU delivers the signals  $V_y = V_{max} \cdot \sin(\alpha + \beta)$ ;  $V_x = V_{max} \cdot \cos \alpha$ , where α is the azimuth, that a corrected signal  $V_{y,corrected} = V_{max} \cdot \sin \alpha$  is desired,

and using the trigonometric relationship  $\sin(\alpha + \beta) = \sin \alpha \cdot \cos \beta + \cos \alpha \cdot \sin \beta$ ,

the corrected V<sub>y</sub> is:

$$V_{y,corrected} = \frac{V_y}{\cos \beta} - V_x \cdot \tan \beta \tag{8}$$

**5.5 Circuit Design**

Figure 15 shows a circuit for one SCU channel (i.e. one field direction Hx or Hy), including pre-amplification, offset compensation by flipping and temperature compensation of sensitivity by electro-magnetic feedback.

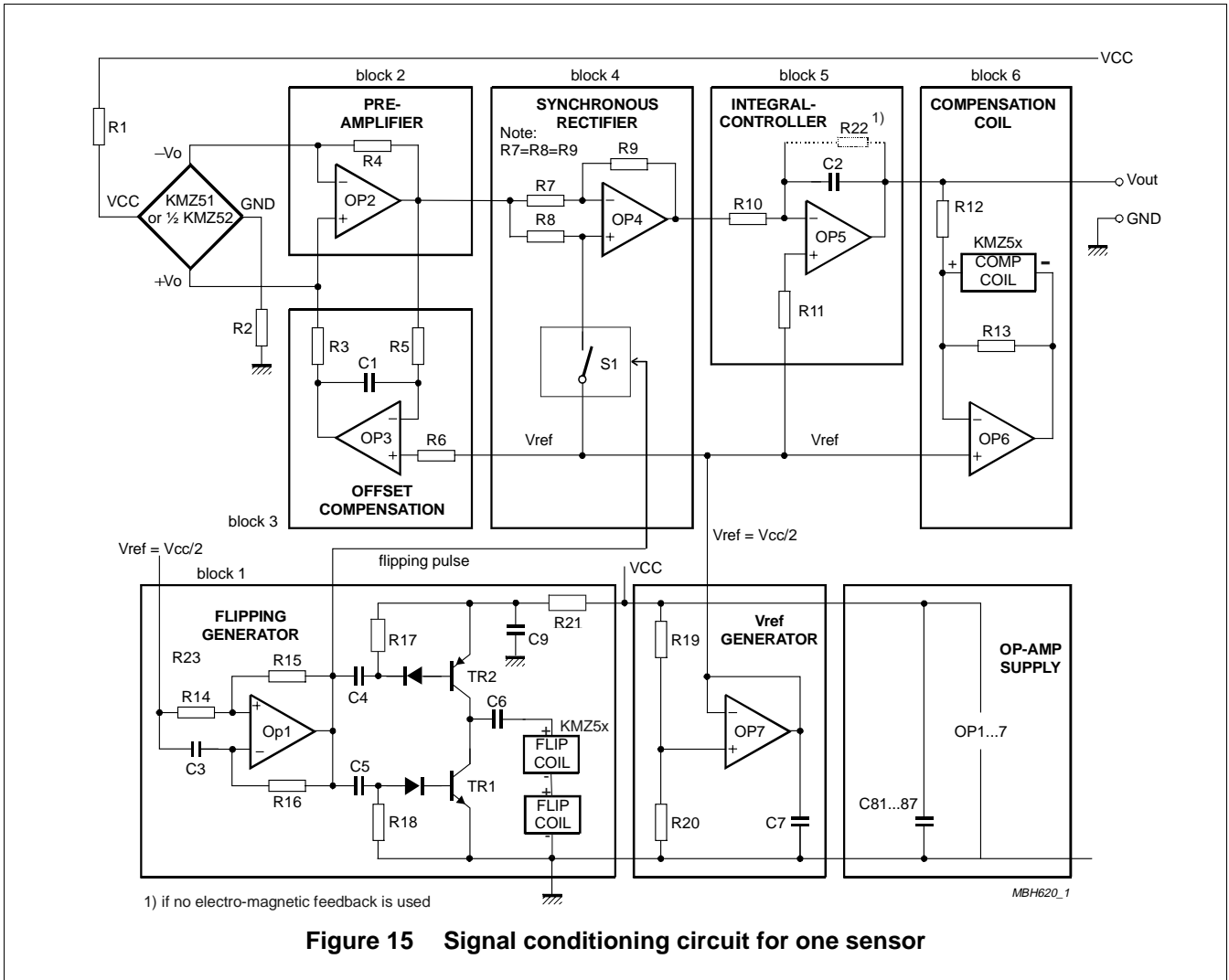

**Figure 15 Signal conditioning circuit for one sensor**

In the following, a design guideline for the circuit blocks is given. A complete, dimensioned SCU circuit based on Figure 15 are given in [3] and [4]. It should be noted, that this is an application example, which is not optimized. For product development, the design hints given here should be considered carefully.

**5.5.1 Supply voltage considerations**

The recommended supply voltage for the KMZ52 is 5V. As the sensor output voltages are ratiometric, both sensor elements should be connected to the same supply. For the flip coil driver, a supply of 10V is recommended to drive the required current of typ. 1A through the series connection of both set/reset coils, which may have a total resistance of up to 6Ω. The supply lines of flipping generator and signal circuitry should be carefully decoupled from each other in order to suppress flipping noise at the signal outputs.

The circuit of Figure 15 only requires a single external supply of  $V_{cc} = 10V$ . The flipping generator is supplied from here via decoupling network R21-C9. C9 should deliver the positive flipping current pulses, thus a

capacitor of some  $\mu\text{F}$  with low series resistance (e.g. Ta Elco) is recommended here. The time constant  $R21 \cdot C9$  must allow  $C9$  to charge up to approximately  $V_{cc}$  between the positive pulses, i.e. during the period of the clock generator. The 5V sensor supply is derived from  $V_{cc}$  by series resistors  $R1$  and  $R2$ . A symmetrical OP-Amp supply is provided by connecting the OP-Amp supply pins to  $V_{cc}$  and GND respectively and connecting their reference inputs to  $V_{cc}/2$ , generated by the  $V_{ref}$  generator.

**5.5.2 Flipping generator (block1)**

This block generates the flipping current pulses at a repetition frequency, determined by  $R16$  and  $C3$ . The frequency is not critical, considering the flipping function itself. The choice of frequency is a trade-off between average current consumption on the one hand and response time and output ripple on the other hand. A frequency of approximately 1 kHz has proved to be a reasonable compromise. As the output of OP1 passes from high to low,  $C4/R17$  produce a pulse that switches  $TR2$  on. This charges  $C6$  and a short positive pulse is passed to the flipping coil. For a low-to-high transition at the output of OP1,  $C5/R18$  forces  $TR1$  to conduct, discharging  $C6$  and providing a negative current pulse through the coil. KMZ51 and KMZ52 both require flip current pulses of typically  $\pm 1\text{A}$  for a duration of  $3\mu\text{s}$ . To drive that current controlled by the OP output,  $TR1$  and  $TR2$  should be Darlington transistors. For a complete SCU, the flipping generator is only required once and the flip coils of both sensors are connected in series. The function of decoupling network  $R21-C9$  is described under supply voltage considerations.

For product development, it is recommended to use an improved flipping circuit like that shown in Figure 16. Here, an active current limiting provides, that the magnitude of the flip current pulses is independent of flip coil resistance. Thus, this circuit is insensitive to spread of flip resistance or supply voltage.

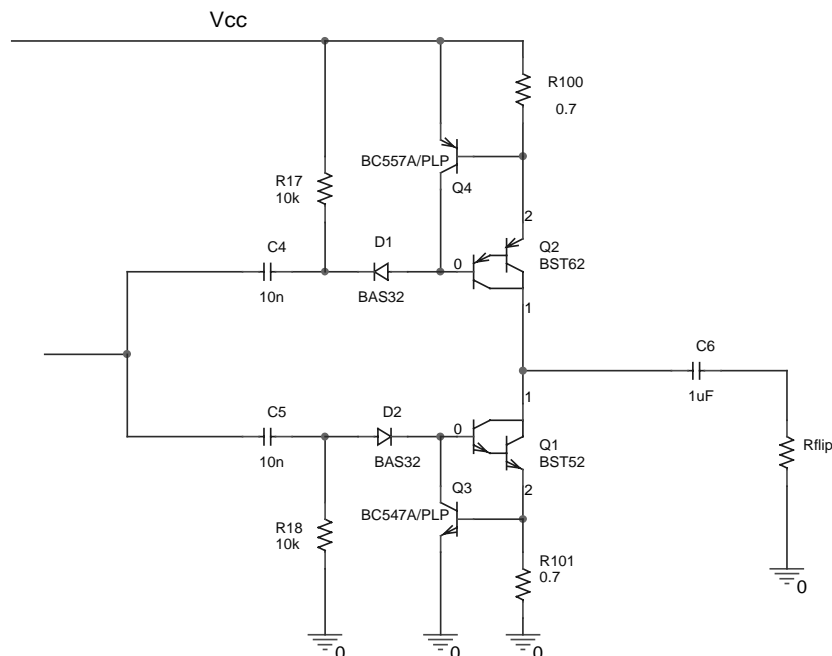

**Figure 16 Flip circuit with active current limiting**

### 5.5.3 Pre-amplifier (block 2)

The flipped sensor signal is amplified here by a factor of  $R4/R_{bridge}$ , where  $R_{bridge}$  is the resistance of the sensor bridge. Due to the electro-magnetic feedback used in this circuit, the pre-amp's output will be virtually zero, when the closed loop control has settled. However, it should be provided that OP2 is operated in its linear range during transient processes of the closed loop control, e.g. after turn-on of the system. Thus, the pre-amplification should be set, such that OP2's output is in its linear range, when the control loop is interrupted, even at maximum sensor signal plus max. offsets. An amplification of approximately 100 is a recommendable value.

### 5.5.4 Offset compensation (block 3)

The low pass filter around OP3 extracts the offset, which is the dc component of the flipped output signal (refer to Figure 12) and feeds it as negative feedback to OP2. The sensor offset is compensated this way. Principally, this could also be done by means of a capacitor between sensor and pre-amp, however the method shown here is preferable, as it compensates the offsets of both the sensor and OP2 simultaneously. This allows to use a low cost op-amp instead of a special low-offset type, thus reducing system cost. The determination of the filter cut-off frequency is a trade-off between smoothing of the output signal and response time.

### 5.5.5 Synchronous rectifier (block 4)

This block recovers the desired dc signal from the flipped ac signal. Provided that  $R7=R8=R9$ , this block performs an alternating +1 and -1 amplification, depending on the state of switch S1, which is controlled by the flipping generator. Thus, each time the output of OP2 changes polarity due to the flipping, this block causes an additional change of polarity, resulting in a rectification.

### 5.5.6 Integral controller (block 5)

This block forms the integral part of the PI-controller, built together with block 6 to drive the compensation coil for electro-magnetic feedback. An integral characteristic is required in the control loop, to force the remaining error - which is the sensor output signal - to zero. Dimensioning the time constant  $R10 \cdot C2$  is a trade-off between response time and smoothness of output signal.

### 5.5.7 Compensation coil driver (block 6)

Forms the proportional part of the PI controller for electro-magnetic feedback including current source for the compensation coil. When the control loop has settled, i.e. when the compensation coil generates a field with equal magnitude and opposite sign to the respective earth's field component, ( $H_{ex}$  or  $H_{ey}$ ), the output voltage  $V_{out}$  is:

$$V_{out(x,y)} = H_{e(x,y)} \cdot \frac{R12}{A_{comp}} \quad (9),$$

where  $A_{comp}$  is the field factor of the compensation coil (refer to the data sheet of KMZ5x). Equation (9) shows the desired effect of the electro-magnetic feedback:  $V_{out}$  is independent of sensor sensitivity and its temperature drift (KMZ52: typ. 0.31%/K). The temperature drifts of  $R12$  and  $A_{comp}$ , which now affect the output voltage are significantly lower. Typical values are 0.02%/K down to 0.005% for standard or precision smd resistors and 0.01%/K for  $A_{comp}$  of the KMZ52. For  $\Delta S$  compensation,  $V_{out}$  can be made adjustable by using a potentiometer for  $R12$ . Note, that due to the asymmetrical OPAMPs supply,  $V_{out}$  in (9) is the output voltage swing relative to  $V_{ref}$ .

**5.5.8 SCU without electro-magnetic feedback**

If no temperature compensation of sensor sensitivity is required, the electro-magnetic feedback loop can be interrupted by omitting the compensation coil driver (block 6). Block 5 is still required as low pass filter in order to suppress flipping spikes on the signal line. However, a resistor R22 then needs to be connected in parallel to C2 in order to achieve a limited output voltage. The output voltage then is dependent on sensor sensitivity S and SCU amplification. Assuming that the synchronous rectifier (block 4) has an amplification magnitude of 1, the output voltage becomes:

$$V_{out(x,y)} = H_{e(x,y)} \cdot S \cdot \frac{R4}{R_{bridge}} \cdot \frac{R22}{R10} \quad (10)$$

In this case, Vout can be adjusted by varying e.g. R22 or R10.

**5.5.9 SCU with Microcontroller**

Figure 17 shows a block diagram for an SCU, using a microcontroller. From the analogue circuitry shown in Figure 15, only the flip coil driver, pre-amps and - optionally - compensation coil drivers are required. The flipped sensor signals are fed to the  $\mu$ C via an A/D converter. It should be considered, that the resolution at this stage must be higher than the final compass accuracy. Principally the same considerations are valid for the D/A converter, driving the compensation coil driver. For a low-end compass, where accuracy is not critical, the internal 8 bit A/D converter of a low-cost  $\mu$ C could be sufficient. If higher accuracies are demanded, an external A/D converter with higher resolution can be the solution.

Offset compensation can be implemented as software, according to the equations shown in section 5.2. Further optional software features could be a control algorithm for electro-magnetic feedback or non-orthogonality compensation. Besides signal conditioning, the  $\mu$ C software will usually also perform the direction determination and further optional tasks, such as interference field calibration or true north calibration (see respective sections).

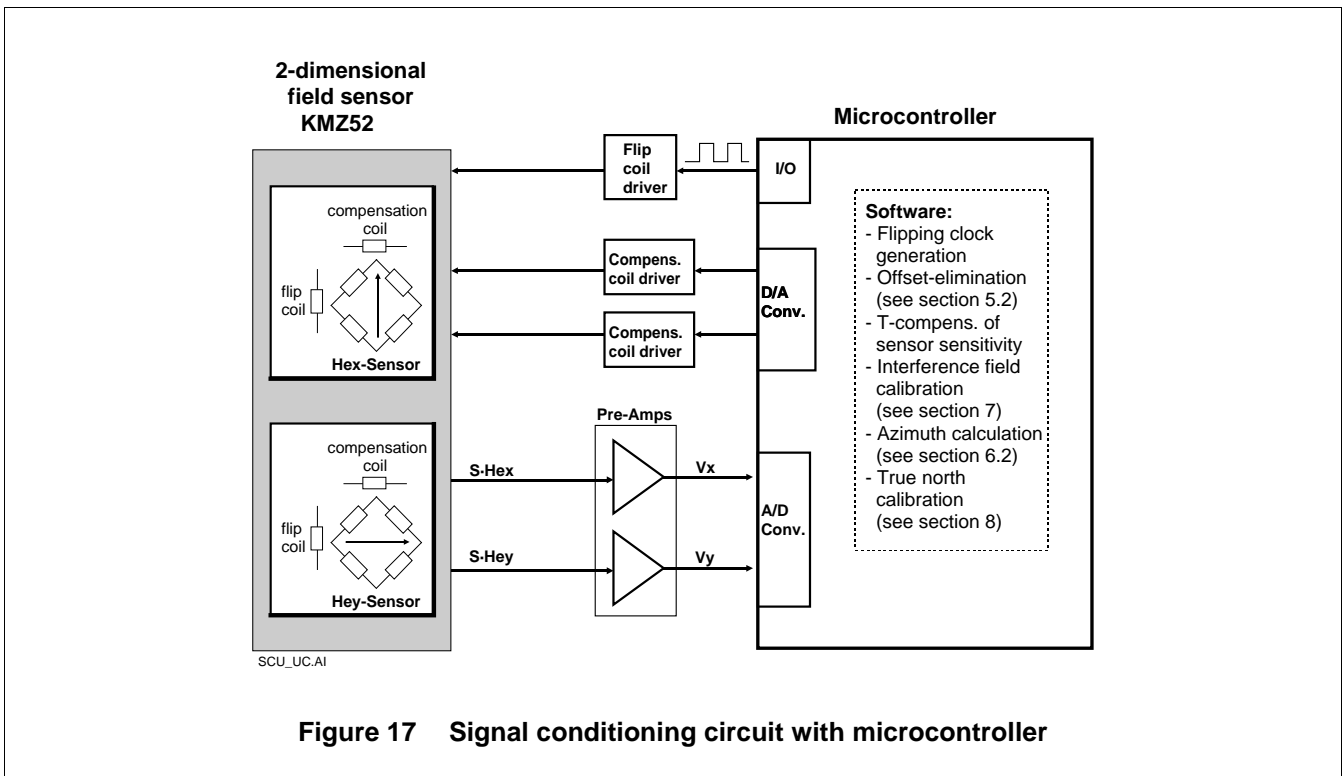



**6. DIRECTION DETERMINATION UNIT (DDU)**

**6.1 8-Segment Compass**

If applications require a rough direction indication only, then a compass set-up is sufficient, which identifies the nearest of the eight cardinal or intermediate points (e.g. N, NW, S, SE, ...). This information can be gained from the SCU outputs without evaluating the arctan function in equation (1). Figure 18 shows the principle. Here the SCU output signals  $V_x$  and  $V_y$  are shown for a full clockwise rotation of the compass. By comparing the SCU signals with the thresholds  $V_{t+}$  and  $V_{t-}$ , logic signals  $N'$ ,  $S'$ ,  $E'$ ,  $W'$  can be derived, which contain the desired information.  $V_{t+}$  and  $V_{t-}$  are equal to  $\pm \sin(22.5^\circ)$ . Figure 19 shows a circuit for the direction determination. As a display, e.g. LEDs can be driven by the respective outputs.

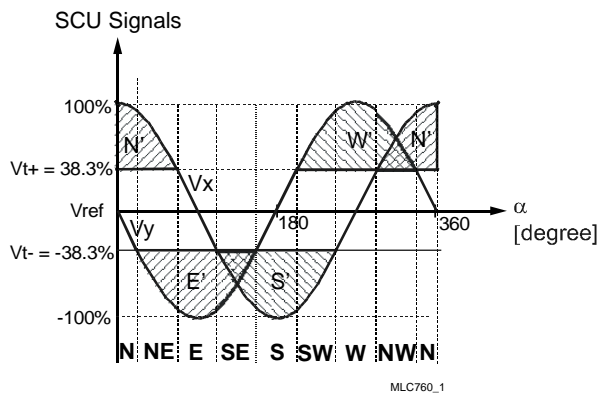

**Figure 18 Direction determination for 8-segment compass**

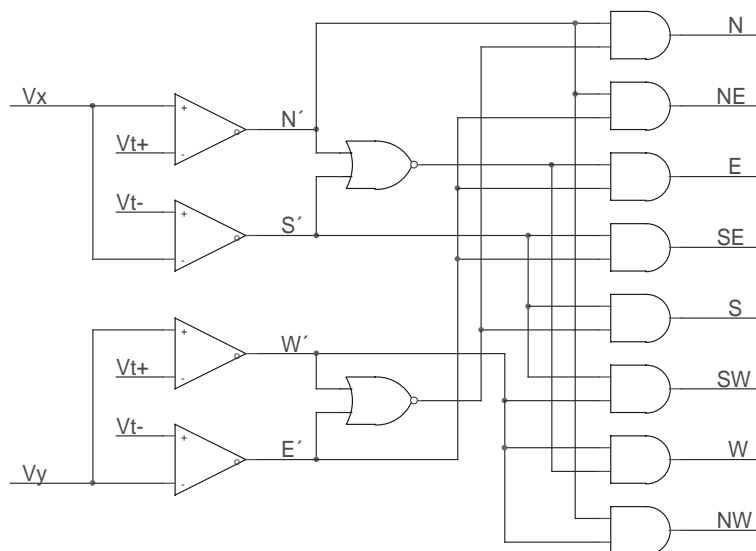

**Figure 19 Circuit for 8-segment compass**

## 6.2 High Resolution Compass

A compass with high accuracy is required for example in navigation systems. Here, the compass together with a measurement of the travelled distance are used to determine the actual position as long as no GPS signals can be received, e.g. while driving between high buildings.

If a direction information with high accuracy is required, e.g. 1 degree or better, then a microcontroller is required for evaluation of equation (1), where Hex and Hey have to be replaced by the SCU output voltages Vx and Vy respectively. It is assumed, that Vx and Vy are corrected with respect to offset, sensitivity difference and, if required, non-orthogonality. When implementing equation (1), it must be considered that the argument Vy/Vx has a pole at Vx = 0, and that the arctan function is uniquely defined only in the angular range of  $-\pi/2$  to  $+\pi/2$ . Thus, the azimuth has to be computed, depending on the actual states of Vx and Vy:

$$\begin{aligned}
 \alpha(Vx = 0, Vy > 0) &= 270^\circ \\
 \alpha(Vx = 0, Vy < 0) &= 90^\circ \\
 \alpha(Vx > 0, Vy > 0) &= 360^\circ - \left(\arctan \frac{Vy}{Vx}\right) \cdot \frac{180^\circ}{\pi} \\
 \alpha(Vx > 0, Vy < 0) &= -\left(\arctan \frac{Vy}{Vx}\right) \cdot \frac{180^\circ}{\pi} \\
 \alpha(Vx < 0) &= 180^\circ - \left(\arctan \frac{Vy}{Vx}\right) \cdot \frac{180^\circ}{\pi}
 \end{aligned} \tag{11}$$

Equations (11) are based on the convention, that the azimuth is counted clockwise from north to the heading direction.

A very efficient way of computing trigonometric functions like arctan is the CORDIC (COordinate Rotating Digital Computing) algorithm. Its efficiency is based on the fact, that it only uses low-end functions like adding, shifting and reading of look-up tables. Basic information and implementation hints for the CORDIC algorithm can be found in the internet.

## 7. INTERFERENCE FIELD CALIBRATION

In practice, the earth field at the compass may be superimposed by other magnetic fields or distorted by nearby ferrous materials. An efficient compensation of such effects is required in order to achieve reliable azimuth readings.

As for any sensor system, only errors caused by deterministic interference sources can be compensated. In this case, deterministic means, that the interference source is at a fixed position relative to the compass and that its magnitude is constant versus time. Thus, as an example, a compass in a car could be compensated for the interference effects caused by the car body. On the other hand, a compass cannot be compensated for non-deterministic error signals, such as the field of another vehicle passing by. However, reading errors caused by such effects can usually be accepted, due to their momentary nature. To avoid misleading readings, a “low pass characteristic” may help, that suppresses the display of transient azimuth variations. Also a warning signal could be generated at the occurrence of such signals.

The influence of deterministic interference fields on a compass can be assessed by inspection of a test diagram as shown in Figure 20. The test diagram is a Lissajous figure, yielded by a 360° rotation of the compass and recording of the SCU output signals  $V_y$  versus  $V_x$ . Without any magnetic interference, the diagram appears as a circle, having its centre at (0,0) and a radius equal to the magnitude  $H_e$  of the earth field. All interference effects appear as a deviation from this shape. Basically, two kinds of interference can occur, called “hard iron effects” and “soft iron effects”. “Hard iron effects” are caused by magnetized objects, which are at a fixed position with respect to the compass. These cause a magnetic field, which is vectorially added to the earth field. Thus, in the test diagram this effect appears as a shift of the circle’s centre to  $(H_{ix}, H_{iy})$ , where  $H_{ix}$  and  $H_{iy}$  are the components of the interference field. “Soft iron effects” occur due to distortion of the earth field by ferrous materials. This effect is dependent on compass angle. Therefore, it appears as a deformation of the circle in the test diagram. Figure 20 shows the effect of both hard iron and soft iron effects on the test diagram.

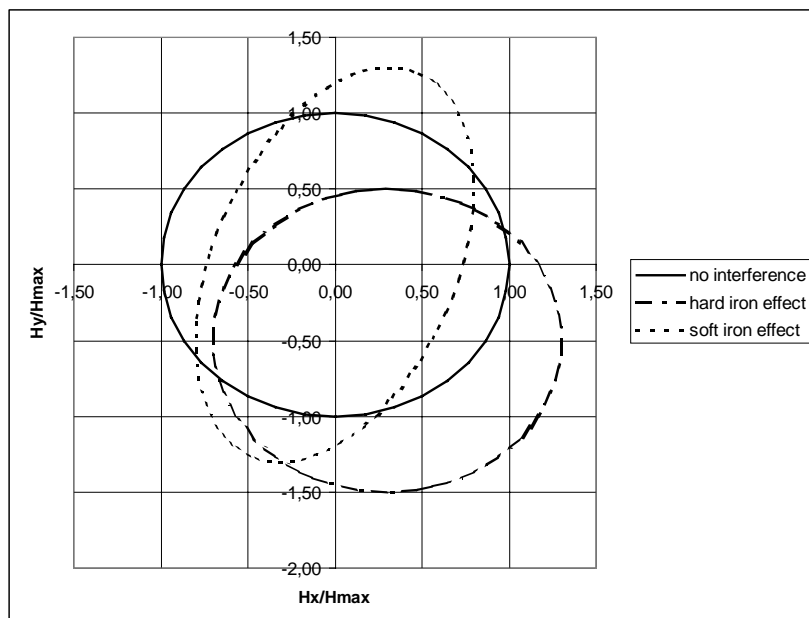

**Figure 20** Typical test diagrams showing hard iron and soft iron effects

In practice, hard iron effects dominate over soft iron effects, provided the use of ferromagnetic materials near the compass can be avoided. To minimize the hard iron effects, a compass should never be installed near objects producing strong magnetic fields. As an example, loudspeaker magnets near the compass may produce

such strong fields, that the amplifiers of the SCU are overdriven. In this case, accurate measurement of the interference field and thus compensation are not possible.

Interference field compensation ideally means, to convert the shifted and/or deformed test diagram into a circle around the centre (0,0). Therefore, the interference field effect has to be measured and in the following, the compass readings have to be corrected considering the measurement results. Generally, this calibration procedure should be carried out individually for each compass. As an example, each individual car has its own "field signature". Even when mounting the same compass into the same environment again, e.g. after maintenance, it is recommended to carry out the calibration again. Thus, the calibration procedure should be simple, ideally automatic. Classical calibration methods, such as using a shielded room to measure the interference field effect without the earth field, or adjusting the compass reading to that of a reference compass, do not fulfill this requirement and will therefore not be discussed here.

Calibration methods become straight forward, if soft iron effects can be neglected compared to hard iron effects. As already pointed out, in this case only the components of a constant interference field have to be measured and compensated. In practice, soft iron effects are usually much weaker, provided there are no ferrous materials at or near the compass. In this case, satisfactory results may be achieved by using the "bidirectional calibration" method. Figure 21 illustrates the principle: Two measurements have to be carried out with the compass at the same location, but at a heading difference of 180°. For both measurements, the respective field components  $H_x$  and  $H_y$  have to be stored. Generally, the field at the compass is equal to the sum of earth field vector  $\mathbf{H}_e$  and interference field vector  $\mathbf{H}_i$ . After a compass rotation of 180°,  $\mathbf{H}_e$  appears with equal magnitude but opposite sign, whereas  $\mathbf{H}_i$  appears unchanged as its source is fixed with respect to the compass. Thus, the vector sum of both measurements  $\mathbf{H}_1 + \mathbf{H}_2$  is:

$$\mathbf{H}_1 + \mathbf{H}_2 = \begin{pmatrix} H_{1x} \\ H_{1y} \end{pmatrix} + \begin{pmatrix} H_{2x} \\ H_{2y} \end{pmatrix} = \begin{pmatrix} H_{ex} + H_{ix} \\ H_{ey} + H_{iy} \end{pmatrix} + \begin{pmatrix} -H_{ex} + H_{ix} \\ -H_{ey} + H_{iy} \end{pmatrix} = \begin{pmatrix} 2H_{ix} \\ 2H_{iy} \end{pmatrix} \quad (12)$$

Rearranging this vector equation, the interference field components as a function of the measured field components are yielded as:

$$\begin{aligned} H_{ix} &= \frac{1}{2}(H_{1x} + H_{2x}) \\ H_{iy} &= \frac{1}{2}(H_{1y} + H_{2y}) \end{aligned} \quad (13)$$

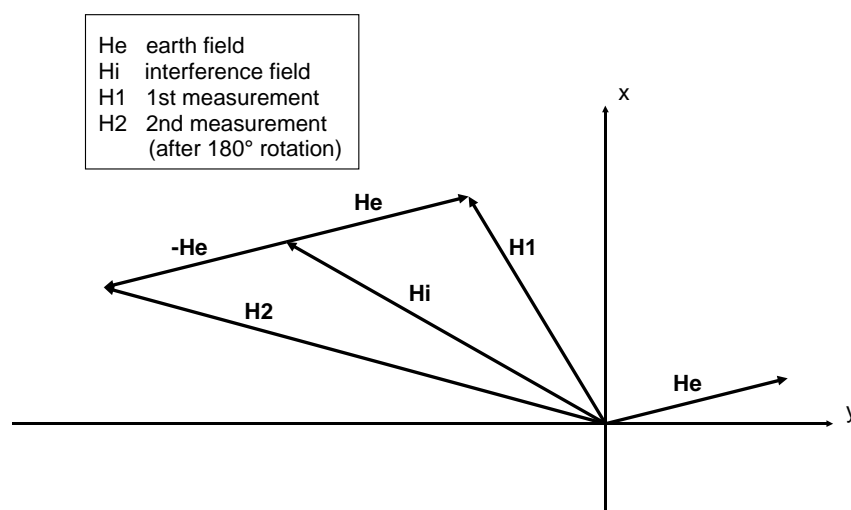

Figure 21 Principle of bidirectional calibration

---

## **Electronic Compass Design using KMZ51 and KMZ52**

## **Application Note AN00022**

---

Once the interference field components have been measured, their effect can be compensated by generating opposite field components  $-H_{ix}$  and  $-H_{iy}$  at the respective sensors. Using Philips magnetoresistive sensors KMZ51 or KMZ52, this task can be fulfilled straight forward by applying appropriate currents to the compensation coils of the respective sensors. In systems using a microcontroller, the compensation can be done by subtraction of the interference field components from the respective sensor output signals.

The bidirectional calibration method can principally be implemented in an analog compass system. In that case, analog storage elements are required and a hardware implementation of equation (13). Using a microcontroller, the implementation of calibration procedures is generally simpler.

In applications, where not only hard iron effects, but also soft iron effects have to be compensated, more sophisticated calibration schemes have to be applied. These will not be covered by this application note, however a range of publications is available on that subject.

## 8. TRUE NORTH CALIBRATION

Once the azimuth has been measured with a compass, one has to be aware, that this indicates the heading direction relative to MAGNETIC north. However, in most practical cases, the heading direction relative to GEOGRAPHIC or TRUE north is required in order to allow navigation by means of a map. As the magnetic and geographic poles of the earth do not coincide, the direction of true north and magnetic north can deviate significantly from each other. This deviation is referred to as declination. Declination is defined as angle from true north to magnetic north. The value of declination varies with the position on earth and can be to the east or to the west. East declination means, that the magnetic north direction indicated by the compass is east of true north. Declination also varies over long periods of time, therefore only updated declination data should be used for compensation. Such data for locations world wide can be found at the web site of the National Geophysical Data Center NGDC [1].

In order to compensate for true north, the declination angle at the actual location has to be added to or subtracted from the azimuth reading of the compass. The appropriate operation depends on whether the declination is to the east or to the west.

A practical way for compensation of declination at a certain location or area would be to hold a compass in true north direction (i.e. along a road which exactly heads toward north). The azimuth reading now gives the declination value, that can be used furtheron for compensation.

**9. TILT COMPENSATION**

As pointed out in section 2, it is the horizontal (i.e. perpendicular to gravity) component of the geomagnetic field, that points to magnetic north. To measure this horizontal component, a compass system as described so far must be positioned, such that the sensitive axes of its field sensors are also in the horizontal plane. If however the compass is tilt, i.e. not held horizontally, a reading error occurs. The error magnitude depends on the tilt angle of the compass and on the inclination or dip angle of the earth’s field at the respective location.

Figure 22 helps to gain a basic understanding of the tilt effect and allows to derive the maximum tilt error. Here, x and y are the sensitive axes of the compass and the z-axis is normal to the compass plane. To simplify the illustration, the compass axes here are fixed, such that the x-y plane is parallel to the earth’s surface, whereas the tilt  $\tau$  is “simulated” as a rotation of the earth’s field relative to the compass. A further simplification has been made, in that without tilt ( $\tau = 0$ ) the y-axis coincides with the north-south direction and the x-axis coincides with the east-west direction. Thus, without tilt, the horizontal component of  $H_e$  has only a y-component and correctly points towards north. For a tilt along the north-south axis (i.e. with east-west as rotation axis), the horizontal component of  $H_e$  will vary in magnitude but will still point towards north. Thus, the tilt error is zero. If however a tilt along the east-west axis (i.e. with north-south as rotation axis) occurs, as indicated in the figure, the direction of  $H_e$ ’s horizontal component deviates from north by an angle  $\epsilon$ . For any tilt along an axis between north-south and east-west, the resulting error depends on the “tilt component” along the east-west axis. Therefore, a tilt along the east-west axis, as shown in Figure 22, causes the maximum error.

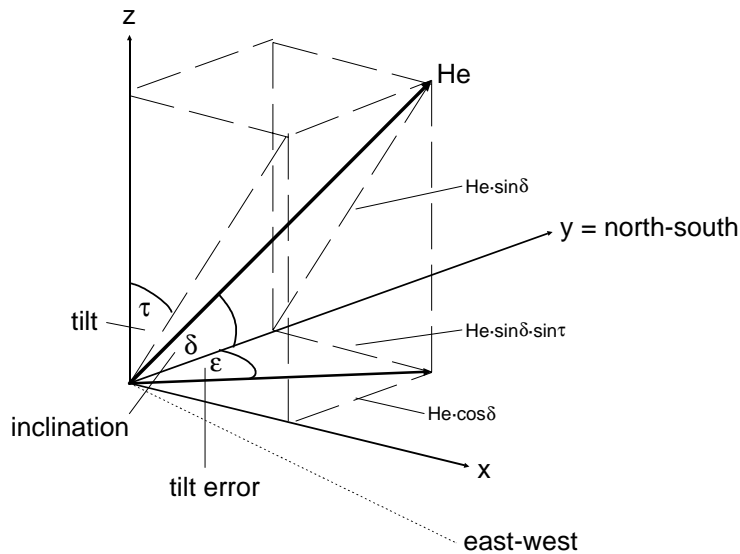

**Figure 22 Tilt error**

Derivation of the maximum tilt error  $\epsilon$  from Figure 22 is straight forward:

$$\epsilon_{max} = \arctan \frac{He \cdot \sin \delta \cdot \sin \tau_{east-west}}{He \cdot \cos \delta} = \arctan(\tan \delta \cdot \sin \tau_{east-west}) \tag{14}$$

This equation is independent of heading direction, thus the simplification in Figure 22, that  $x =$  heading direction, causes no restriction. Equation (14) indicates, that the error increases with both inclination  $\delta$  and tilt angle  $\tau$  and that the error is zero, if inclination and/or tilt are zero. The maximum tilt error occurs for a tilt angle of  $90^\circ$ , where  $\sin \tau$  equals one and therefore the error reaches the magnitude of the inclination  $\delta$ . Figure 23

shows tilt error versus tilt angle for two locations on earth. Inclination values for locations world wide are available at [1].

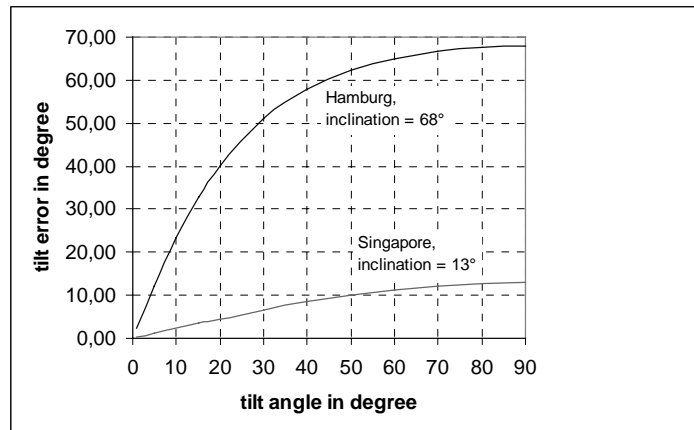
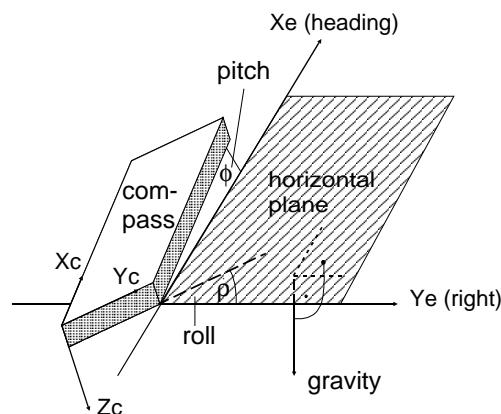

**Figure 23 Tilt error magnitudes**

A classical method for avoiding tilt errors is to put a compass into a liquid, which provides horizontal levelling of the compass due to gravity. This is often referred to as “mechanical gimbaling”. However, as the compass here is not fixed within its housing, interference fields caused by this housing are no deterministic signals anymore and can therefore not be calibrated (refer to section 7).

Tilt error can be compensated without moving parts by converting the measured earth field components mathematically into the horizontal components. This technique is often referred to as “electronical gimbaling” and requires additional sensor elements:

- A third magnetic field sensor, as now all three cartesian vector components of the earth’s field, i.e.  $H_x$ ,  $H_y$ ,  $H_z$  have to be measured.
- Sensors for pitch and roll to detect the tilt status of the compass. Pitch and roll are terms coming from aviation. As shown in Figure 24, pitch refers to a tilt along the x or heading direction (= rotation around the y axis), whereas roll refers to a tilt along the y axis (= rotation around the x-axis).



**Figure 24 Definition of pitch and roll**



## Electronic Compass Design using KMZ51 and KMZ52

## Application Note AN00022

The derivation of the horizontal earth field components  $H_{xe}$ ,  $H_{ye}$  from the measured field components  $H_{xc}$ ,  $H_{yc}$ ,  $H_{zc}$  requires a transformation between two rotated cartesian 3-D coordinate systems (refer to Figure 24). Equations (15) are the result of this transformation:

$$\begin{aligned} H_{xe} &= H_{xc} \cdot \cos \phi - H_{yc} \cdot \sin \phi \cdot \sin \rho - H_{zc} \cdot \sin \phi \cdot \cos \rho \\ H_{ye} &= H_{yc} \cdot \cos \rho + H_{zc} \cdot \sin \rho \end{aligned} \quad (15)$$

Figure 25 gives a simplified block diagram for an electronically gimbaled compass system. Using Philips magnetoresistive sensors, the 3-axes field sensor system can be built up with a dual sensor KMZ52 for the x and y axes and a single sensor KMZ51 for the z axis. For pitch and roll sensing, gravity sensors as compact devices in IC packages are available, realized by combining micro-machining and integrated circuit technology.

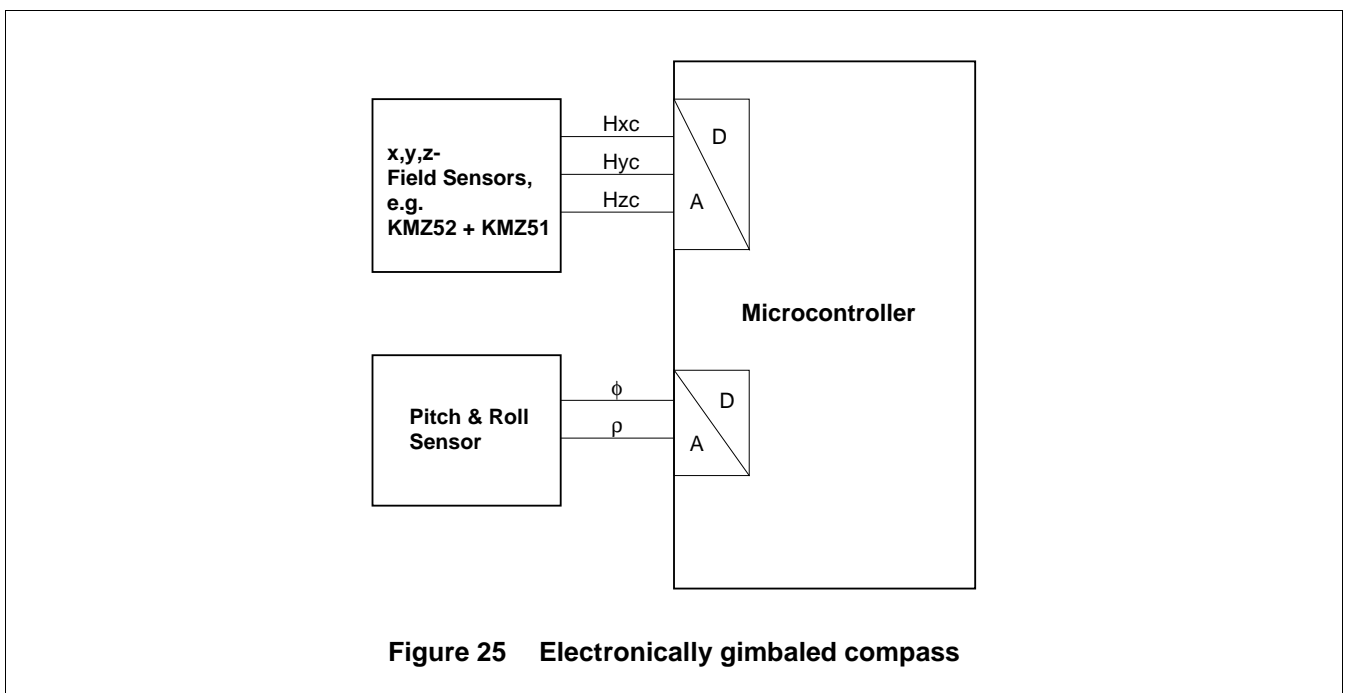

Figure 25 Electronically gimbaled compass

## 10. SYSTEM ACCURACY

Table 2 summarizes the main error influences on a compass system together with methods for calibration, as discussed in the respective sections of this paper. In all equations,  $\alpha$  is the real azimuth.

**Table 2 Summary of errors and calibration methods**

Error source	Resulting azimuth error ( $\alpha - \alpha_{\text{measured}}$ )	Calibration	See section
Offsets $V_{ox}$ and $V_{oy}$ at SCU outputs	$= \left  \alpha - \arctan \frac{V_{max} \sin \alpha + V_{oy}}{V_{max} \cos \alpha + V_{ox}} \right $ $\approx 0.8^\circ / \frac{V_{ox,y}}{V_{max}} [\%]$ Assumption: $V_{ox} = V_{oy}$	Continuous in-circuit calibration by flipping combined with electronic feedback or mathematical correction.	5.2, 5.5
Sensitivity difference $\Delta S$ between SCU channels	$= \left  \alpha - \arctan \left[ \left( 1 + \frac{\Delta S}{S} \right) \tan \alpha \right] \right $ $\approx 0.3^\circ / \frac{\Delta S}{S} [\%]$	Trimming of SCU amplification to achieve equal amplitudes of $V_{out}$ ; if required, in-circuit T-drift compensation by electro-magnetic feedback.	5.3, 5.5
Non-orthogonality, i.e. sensors mounted at $90^\circ \pm \beta$	$= \left  \alpha - \arctan \frac{\sin(\alpha + \beta)}{\cos \alpha} \right $ $\approx 1^\circ / \beta [^\circ]$	Measure $\beta$ as phase difference between SCU output voltages and store it. Mathematical correction during operation.	5.4
Interference field $H_{ix}, H_{iy}$ ("hard iron" effect)	$= \left  \alpha - \arctan \frac{H_e \sin \alpha + H_{iy}}{H_e \cos \alpha + H_{ix}} \right $ $\approx 0.8^\circ / \frac{H_{ix,y}}{H_e} [\%]$	Determine interference fields, e.g. using bi-directional calibration method. Correction mathematically or using compensation coils.	7
Declination $\lambda$	$= \lambda [^\circ]$	Shift zero-point of azimuth reading by $\lambda$ .	8
Tilt $\tau$	$= \arctan(\tan \delta \cdot \sin \tau_{\text{east-west}})$ $\delta$ : inclination angle	Continuous in-circuit calibration by using 3-dimensional compass, pitch and roll sensors and mathematical correction.	9

During trimming for compensation of  $\Delta S$ , soft iron interference fields and tilt should be avoided, as these effects would also appear as a difference in SCU output amplitudes.

In systems using a microcontroller, further errors occur, mainly due to quantization and non-linearity of the A/D converter.

As the individual errors described above are random quantities and independent of each other, the total system error can be found by applying the error propagation law:

$$E_{tot} = \sqrt{E_1^2 + E_2^2 + \dots + E_n^2} \quad (16)$$

**11. APPLICATION EXAMPLES**

Following block diagrams represent ideas for the realization of complete compass systems. The functional blocks for signal conditioning and direction determination shown here have been described in earlier sections of this paper.

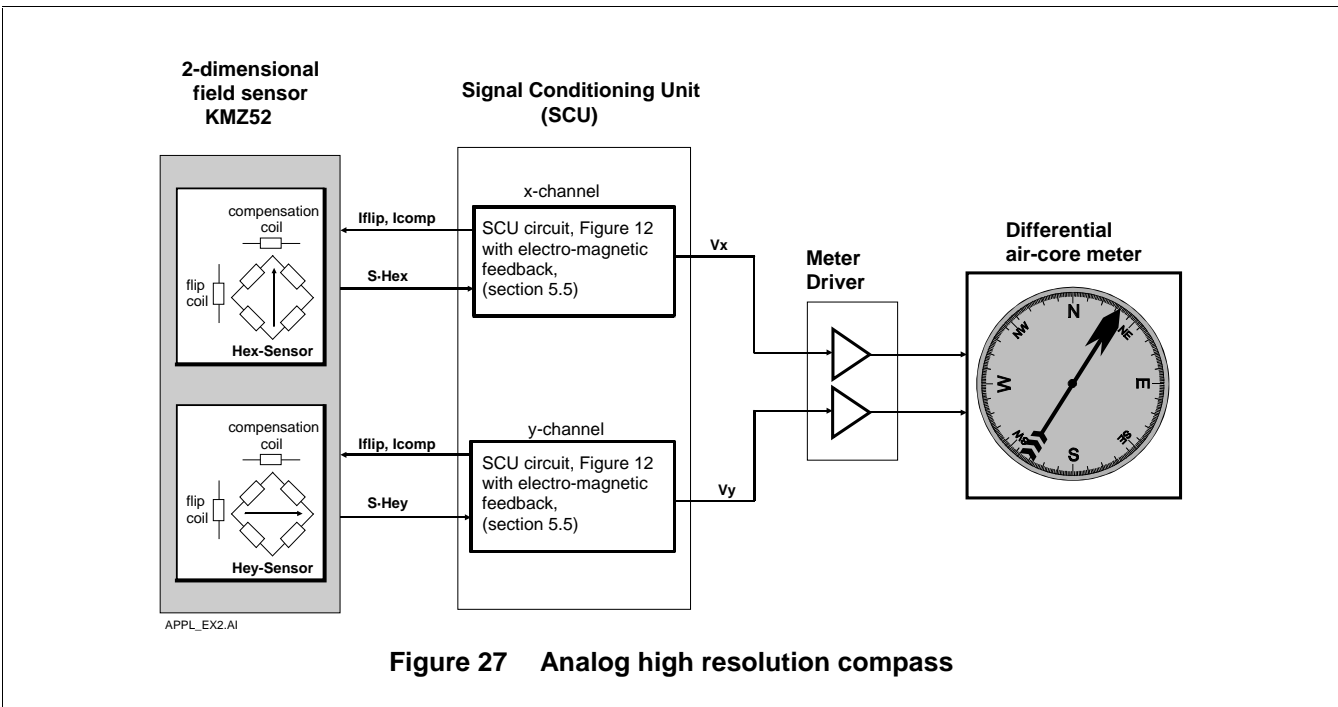
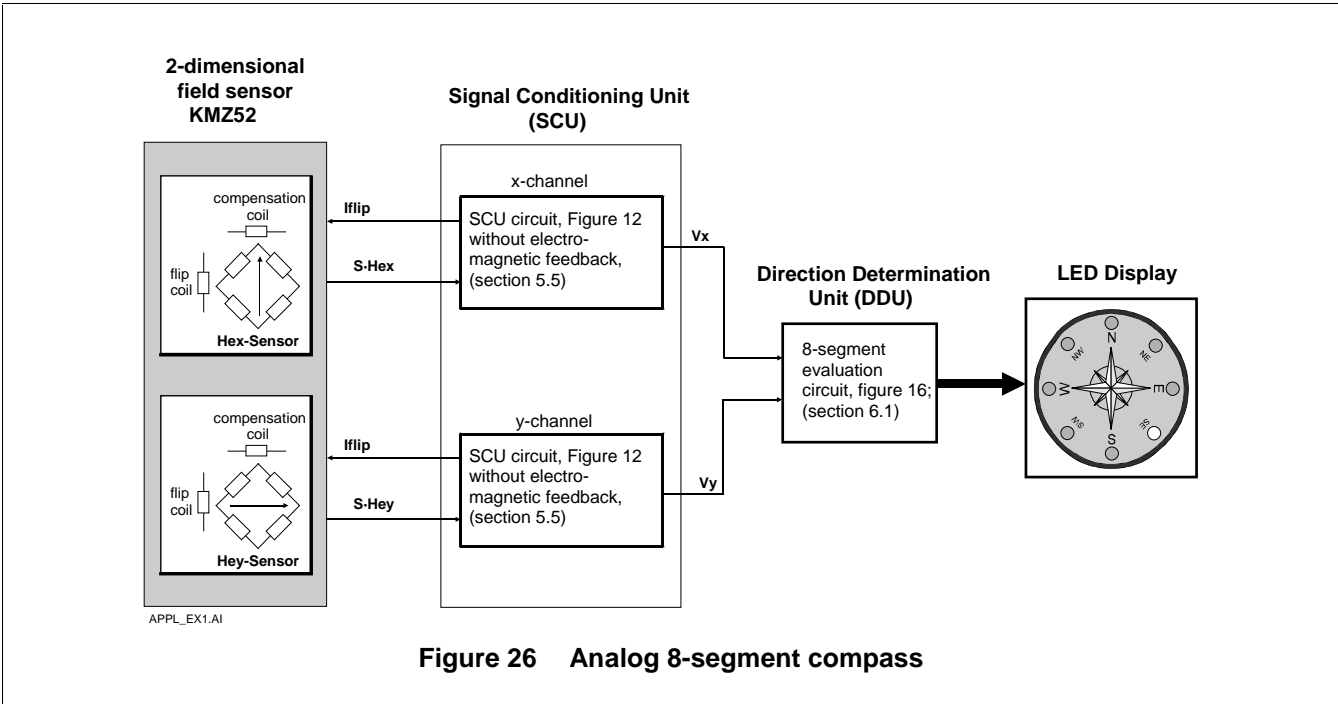

# Electronic Compass Design using KMZ51 and KMZ52

# Application Note AN00022

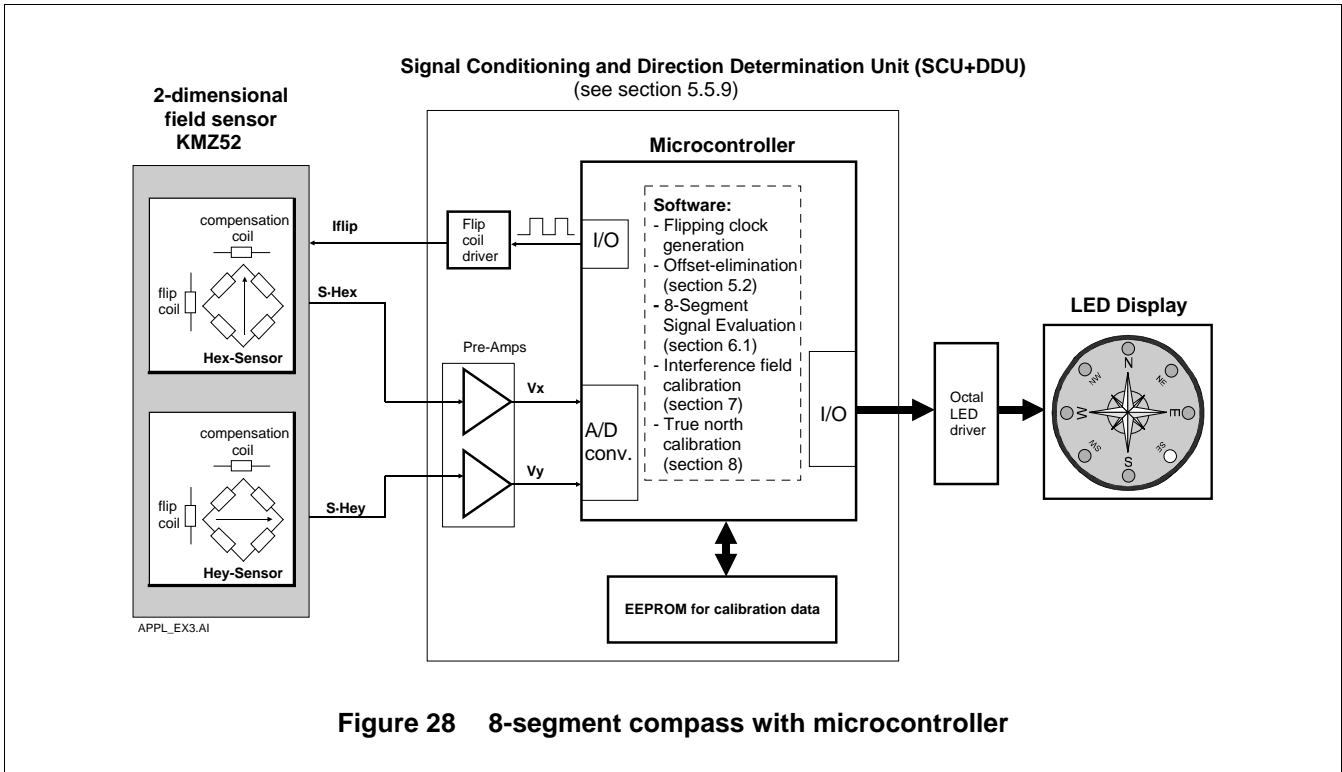

**Figure 28 8-segment compass with microcontroller**

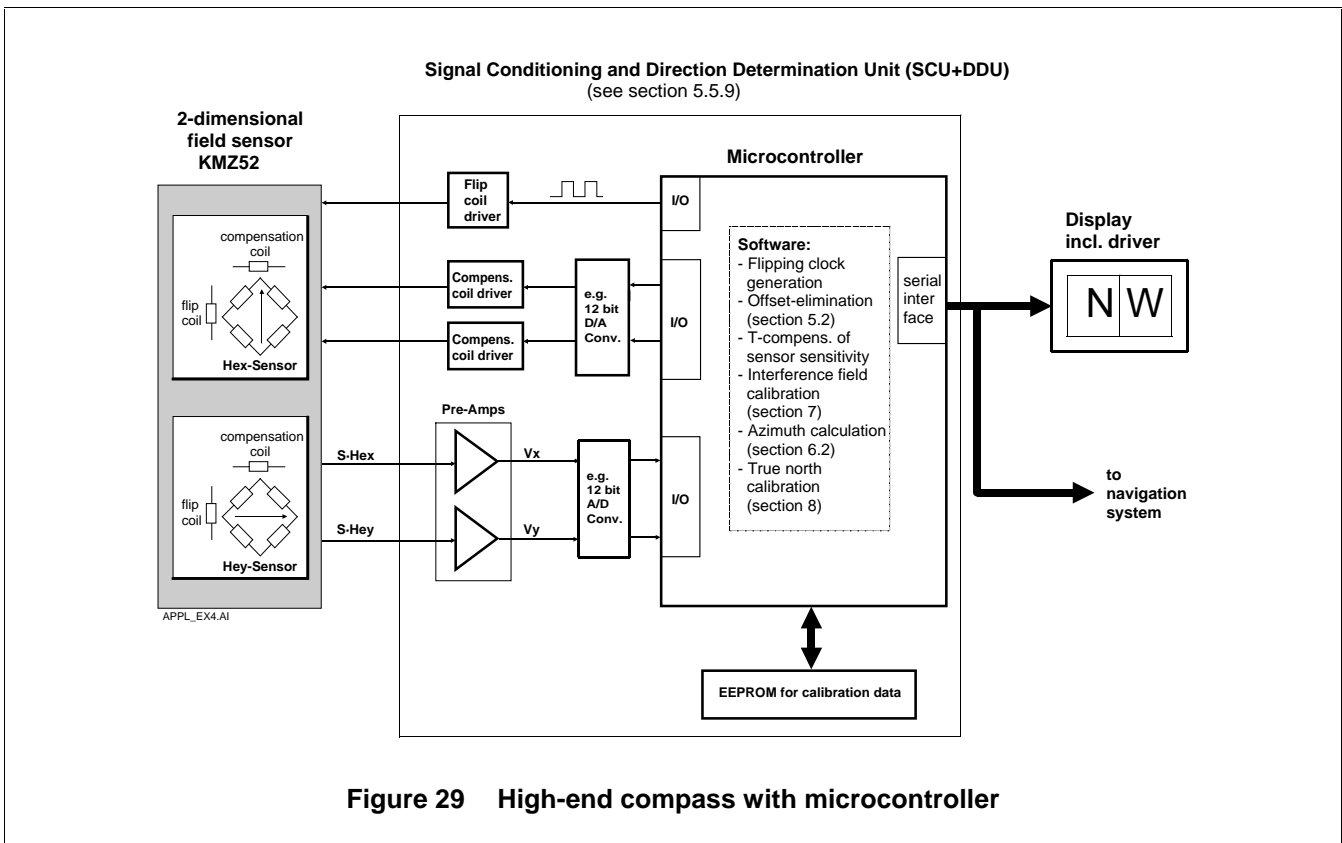

**Figure 29 High-end compass with microcontroller**

## 12. REFERENCES

- [1] Status Report of Repeat Data At the WDC-A,  
(Summary of data from geophysical observatories world wide)  
<http://www.ngdc.noaa.gov/seg/potfld/mrepeat1.shtml>
- [2] Data sheet: KMZ52 Magnetic Field Sensor  
Philips Semiconductors
- [3] Data Handbook SC17 including CD-ROM: Semiconductor Sensors  
Philips Semiconductors, 1998
- [4] Web site of Philips Semiconductors  
[http://www.philips.semiconductors.com/handbook/various\\_39.html](http://www.philips.semiconductors.com/handbook/various_39.html)

**APPENDIX 1 List of abbreviations**

H	magnetic field vector
H	magnetic field strength
$H_e(x,y)$	magnetic field strength of earth's field (x,y component)
$H_i(x,y)$	magnetic field strength of interference field (x,y component)
S	sensitivity (of sensor element or SCU channel)
SCU	signal conditioning unit
DDU	direction determination unit
$V_{oy,x}$	SCU offset voltage (x or y channel)
$V_{y,x}$	SCU output voltage (x or y channel)
$\Delta S$	sensitivity difference between SCU channels
$\alpha$	azimuth angle, exception: section 4: angle between current and magnetization within a magnetoresistive element
$\beta$	non-orthogonality of sensor system
$\delta$	dip or inclination angle
$\varepsilon$	tilt error angle
$\phi$	pitch angle
$\lambda$	declination angle
$\rho$	roll angle
$\tau$	tilt angle

**APPENDIX 2 Unit conversions**

$$1 \text{ Tesla} = 10^4 \text{ Gauss} = 10^9 \text{ Gamma} = 7,96 \cdot 10^5 \text{ A/m}$$