

WR155 MOD and TUNE-UP FOR ESS RADIOS

APPROX. 33 WATTS @ 13.8 VOLTS

These WR155 radios have been modified for 4 channel use with the addition of a Model OS-4 4 channel oscillator board which fits in the front top of the radio over the power supply board (See Fig. 1 & Fig. 3). Some of the radios have also been equipped with a 4 channel tone CTCSS encoder board (Model S-4T) which will not be used for ESS radios (unless sub-audible tones are required). If your radio has one, it will be located at the front of the radio behind the speaker grill.

All radios have been used in the 138-150 MHz bands and, therefore, require no changes to the capacitors in any of the tank circuits.

Receive/Transmit crystal calculations are as follows:

TRANSMIT

RECEIVE

$$\frac{\text{Carrier Freq.}}{6} = \text{Xtal Freq.} \\ (24\text{MHZ}-24.666\text{MHZ})$$

$$\frac{\text{Carrier Freq.} - 10.7}{3} = \text{Xtal Freq.} \\ (44.4355-45.7666\text{MHZ})$$

EXAMPLE: VE7TEL 145.170 - 600 (REPEATER)

TRANSMIT

RECEIVE

$$\frac{144.570}{6} = 24.095\text{MHZ}$$

$$\frac{145.170 - 10.7}{3} = \frac{134.47}{3} = 44.82333\text{MHZ}$$

- 1) To start off, either remove the S-4T CTCSS board or disable by cutting "Tone-Out" white-green wire from the S-4T board (See Fig. 2).
- 2) Insert crystals in OS-4 4 channel oscillator board (See Fig. 1).
- 3) Align transmit and receive by following attached instructions.

TRANSMITTER

1. Test equipment

Directional wattmeter and dummy load or termination wattmeter (50 ohms, approx. 50 watts).

2. Preparation for adjustment (Refer to Paragraph 6)

Connecting the wattmeter to the antenna connector and the microphone to the mic. connector, confirm that the input voltage is 13.6 volts. Turning the power ON OFF switch on, press the push-to-talk button of the transmitter to start transmitting. The keying time should be as short as possible (less than one minute) until the transmitter has been fully aligned.

3. Adjustment procedure

(Refer to the equipment adjustment points and test points diagram located on the rear of the top cover or Fig. 18)

3 of 4

Procedure	Test Points	Multimeter		Meter		Adjusting Point	Tuning
		⊕	⊖	Range (V)	Reading (V)		
Step-1 A	TP1	TP1 (Note 3)	Ground	.3	0.1 - 0.15	L1 - L2	70% of maximum (along the direction of increasing of inductance)
STEP 1 B	TP101	TP101	GND	3	1 - 1.5	L103	MAXIMUM
Step-2	TP102	TP102	Ground	5	1.8~3.0	L104~L106	Maximum
Step-3	TP103	TP103	Ground	0.5	0.08~0.18	L107~L108	Maximum
Step-4	TP104	+B1 (Note 1)	TP104	5	1.3~2.3	L109.L110.L112. C158.C159.C161	Maximum
Step-5	Repeat Step-1, 2, 3 and 4 several times.						
Step-6	Watt-meter				35~40W		
Step-7	Watt-meter				30~33W	R305 (Note 2)	

Note 1. +B1 indicates 11.5 volts line. (TP104 LOCATED ON BOTTOM OF TRANSMIT BOARD SEE FIG 4)

Note 2. Transmitter output adjustment.

Adjust of output power by R305 to 33 watts approximately (+ B1 is approximately 11.5 volts then.)

Note 3.

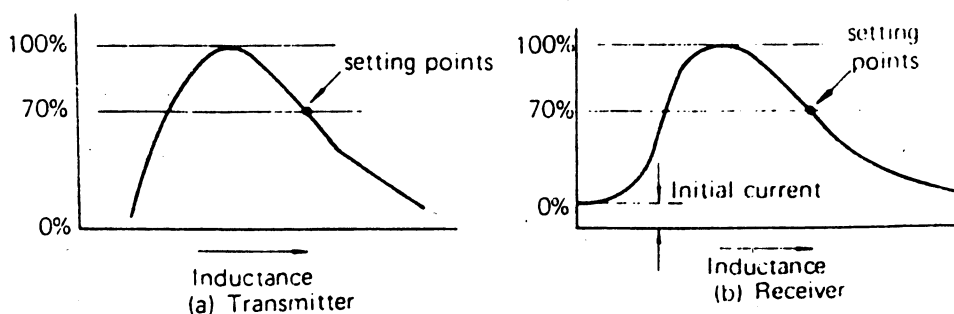

RECEIVER

1. Test equipment

Signal Generator (S.G.)

Distortion analyzer (AF voltmeter). Crystal controlled oscillator for 10.7 MHz check (called 10.7 MHz checker hereafter).

Multimeter and adjusting screwdrivers.

2. Adjustment procedure (Refer to the equipment adjustment points and test points diagram located on the rear of the top cover or Fig. 1B).

Procedure	Test Points	Multimeter		Meter		Adjusting Point	Tuning
		⊕	⊖	Range (V)	Reading (V)		
Step-1 A	TP2	TP2 <small>NOTE 3</small>	Ground	1	0.4 - 0.6	L3	70% of maximum (along the direction the core is inserted)
STEP 1 B	TP202	TP202	GND	1	0.5 - 0.7	L4 - L214	MAXIMUM
Step-2	TP204	TP204	Ground	0.1	0.15 ~ 0.25	C243, C246	Maximum
Step-3	TP201	TP201	Ground	(0.1) 50μA	(Note 4)	L206, L207 L208, C203 C205, C210 C211, C212 C257, C259	Maximum
Step-4	TP205	TP205	Ground	50μA	0 ± 1μA	L209, L210 (Note 5)	0 ± 1μA

Note 4. Sensitivity

Connect S.G. to the antenna, adjust S.G. output level to 3 (10 dBμ) - 15 (24 dBμ) microvolts (where the meter TP201 does not saturate), adjust the beat sound to zero with the 10.7 MHz checker, then turn off the checker. Then adjust L206 ~ L208, C203, C205, C210, C211, C212, C257 and C259 for maximum indication at test point 201.

Note 5. Adjustment of the discriminator

- (1) Set the noise output at the absence of a signal to less than approx. 0.1 watt.
(Adjust by the volume knob [VOLUME] of the controller).
- (2) Adjust the S.G. signal level 1000 microvolt modulated 3 kHz deviation.
- (3) Adjust the audio frequency output to be maximum by the primary coil L209 of the discriminator.
- (4) Adjust the amplitude of TP205 to be zero by the secondary coil L210.
- (5) Repeat the adjustment (3), (4).

WR 155 MODS AND TUNE-UP

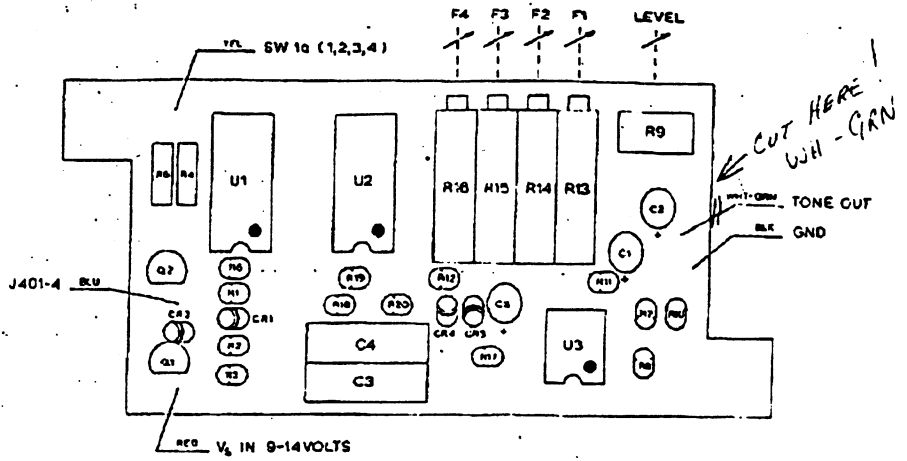

VIEW FROM COMPONENT SIDE

0 1 2 3 4 5 cm

S4T CTSS Board

FIG 2

REV	DATE	DESCRIPTION	ENG	CHKD	DATE
WR WESTERN RADIO SERVICES LTD MICHIGAN ST., CANON					
TITLE: MODEL S-4T 4-TONE CTSS ENCODER PC ASSEMBLY					
DESIGN	DATE	BY	CHKD	DATE	REV
CHECKED	DATE	BY	CHKD	DATE	REV
APPROVED	DATE	BY	CHKD	DATE	REV
					525-2

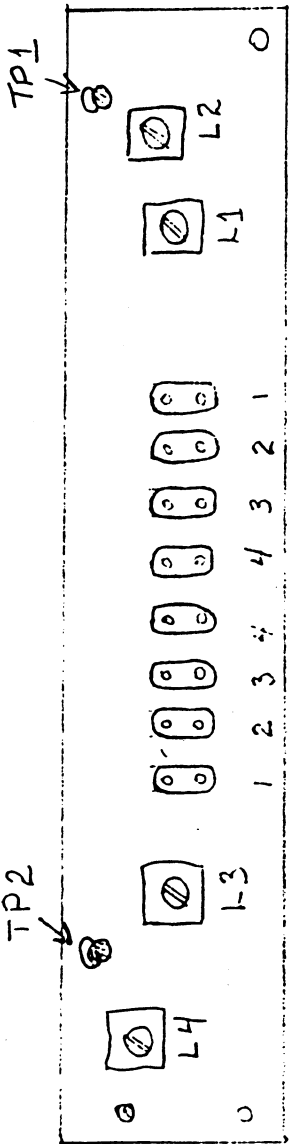

FIG 1

OS4 4CHAN
OSC.

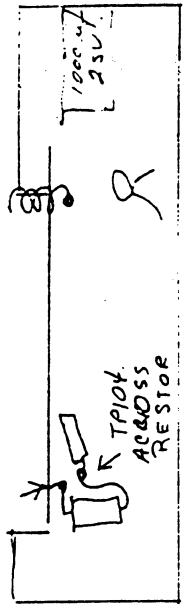
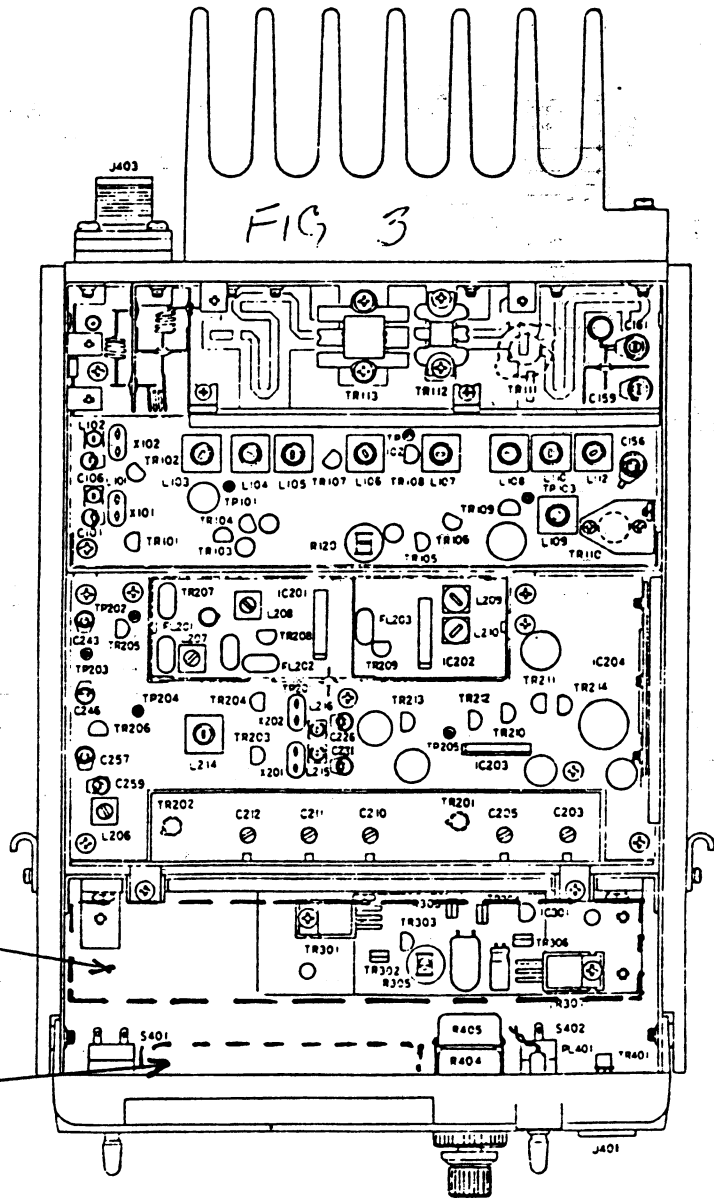

FIG 4 TRANS. BOARD TP 104
BOTTOM SIDE

4CHAN
OSC
BOARD

FIG 1

S-4T
CTSS
BOARD



RECEIVER SCHEMATIC DIAGRAM

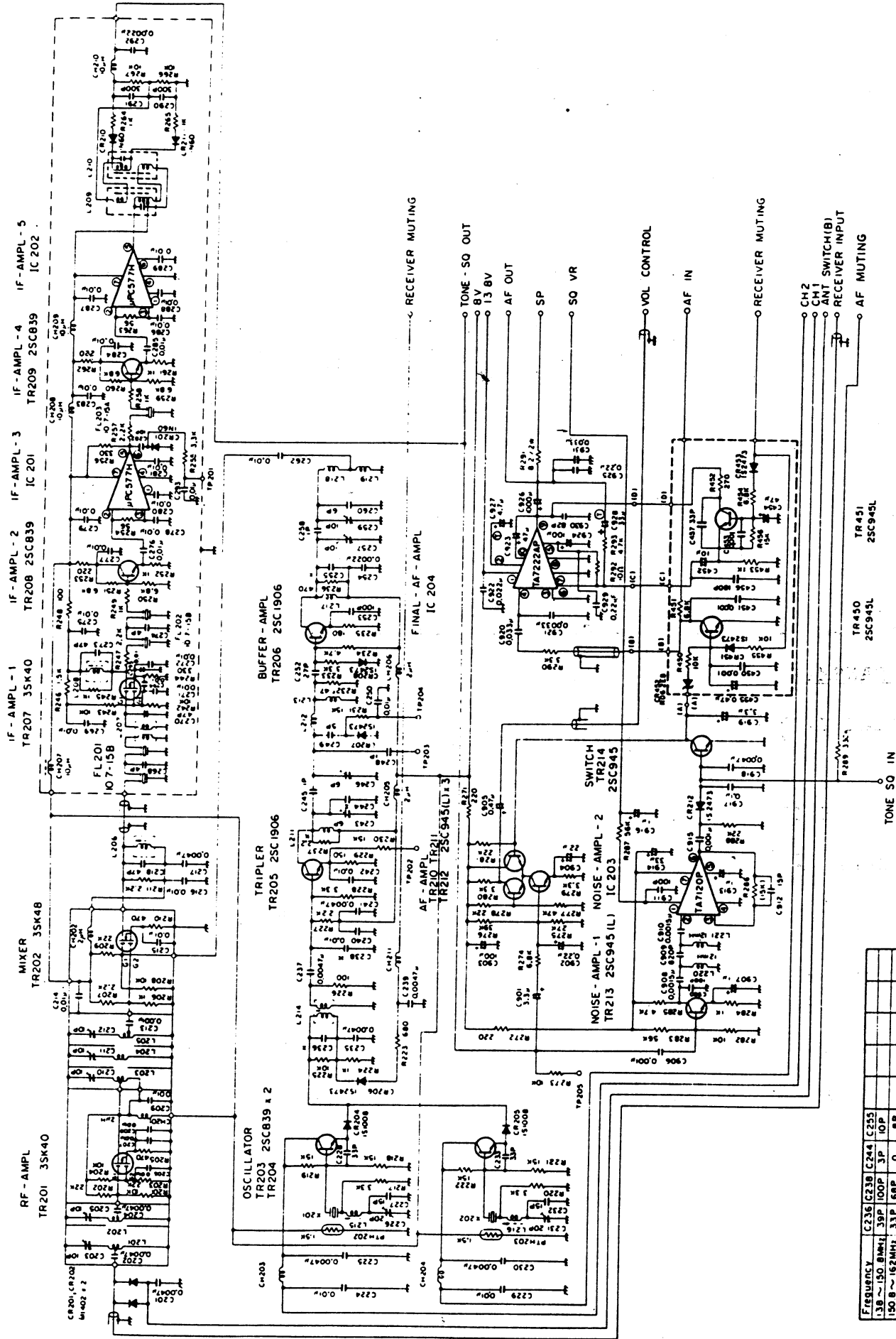
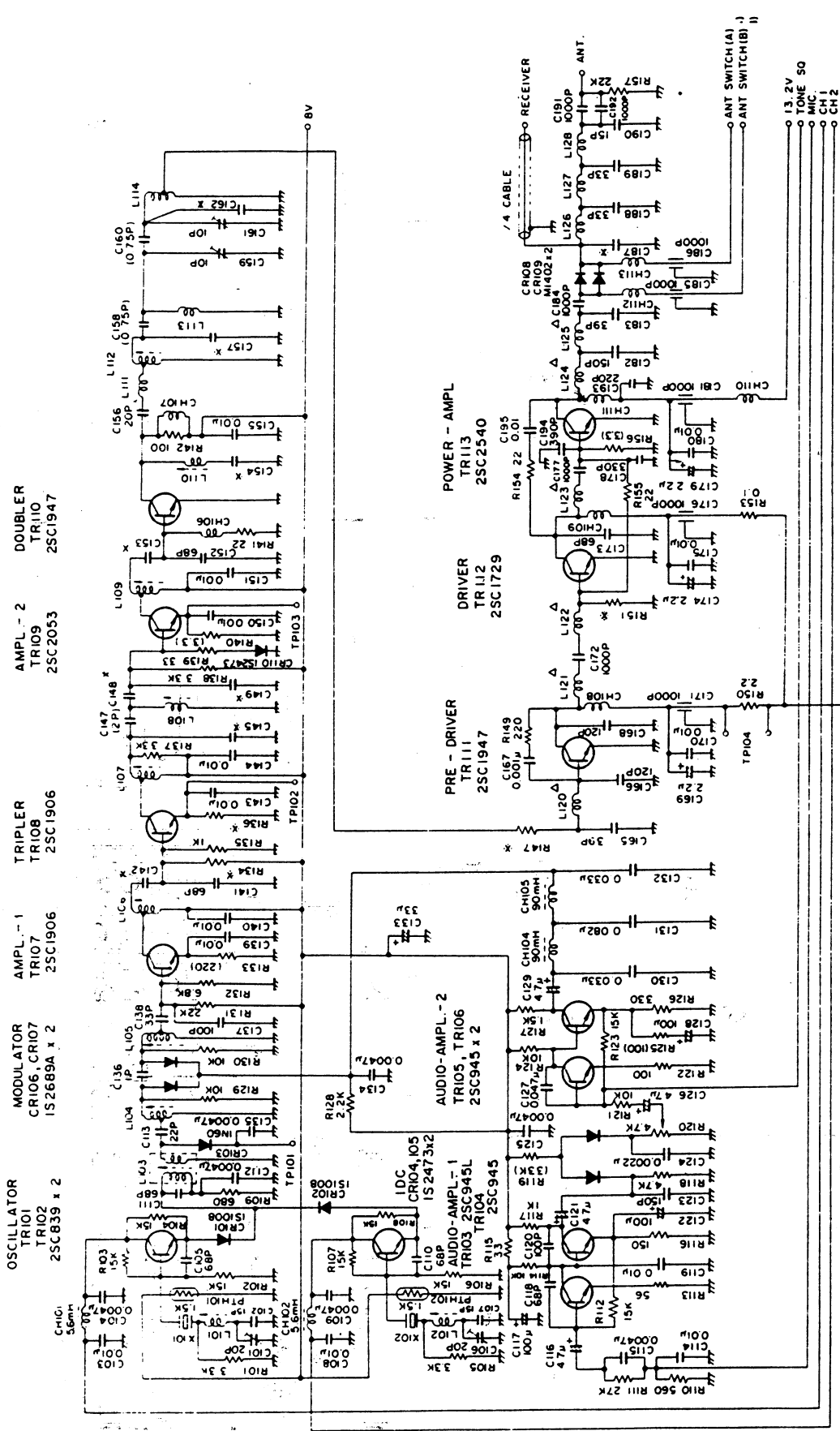

Fig. 13

FREQUENCY	C236	C238	C244	C255
138 ~ 150 MHz	39P	100P	3P	10P
150 B ~ 162 MHz	33P	68P	0	6P
162 ~ 174 MHz	27P	56P	0	6P

() : These values may vary from set to set
 X : Unless otherwise specified all resistors are in ohms all capacitors are in Farads

TRANSMITTER SCHEMATIC DIAGRAM



- OSCILLATOR
TRI01
TRI02
2SC839 x 2
- MODULATOR
CRI06, CRI07
IS 2689A x 2
- AMPLIFIER-1
TRI07
2SC1906
- TRIPLER
TRI08
2SC1906
- AMPLIFIER-2
TRI09
2SC2053
- DOUBLER
TRI10
2SC1947
- DRIVER
TRI12
2SC1729
- POWER-AMPLIFIER
TRI13
2SC2540

Δ ; These inductors are parts of P.C.B.
 () ; These values may vary from set to set.
 * ; See the table.

Frequency	R03	R136	R147	C142	C143	C145	C154	C157	C162	R151	C187
3.8-60 Mc	50K	180	47	68P	18P	18P	33P	27P	10P	5P	133
50.8-62 Mc	50K	180	101	47P	15P	47P	27P	22P	7P	5P	133
62-174 Mc	50K	180	101	47P	15P	47P	22P	18P	5P	0	133

Unless otherwise specified, all resistors are in Ohms all capacitors are in Farads.

Fig. 9