

FM IF SYSTEM IC

- 3 Stage Differential IF Amplifier.
- Differential Peak Detector.
- Muting Circuit.
- High Recovered Output Voltage : $V_{OD}=500mV_{rms}(Typ.)$.
- Low Distortion : $THD=0.1\%(Typ.)$.
- Wide Operating Supply Voltage Range : $V_{CC}=8\sim 15V(Typ.)$.
- Signal Meter Drive Voltage : $V_3=4V(Typ.)$
- Variable Muting Point.
- Muting Off at Open Terminal.
- Simplified Single Coil Tuning.
- Very Few External Parts.

MAXIMUM RATINGS ($T_a=25^\circ C$)

CHARACTERISTIC	SYMBOL	RATING	UNIT
Supply Voltage	V_{CC}	15	V
Input Voltage	V_{IN}	0.7	V
Power Dissipation (Note)	P_D	750	mW
Operating Temperature	T_{opr}	-25~75	$^\circ C$
Storage Temperature	T_{stg}	-55~150	$^\circ C$

Note : Derated above $T_a=25^\circ C$ in the proportion of $4mW/^\circ C$ for KIA6003S

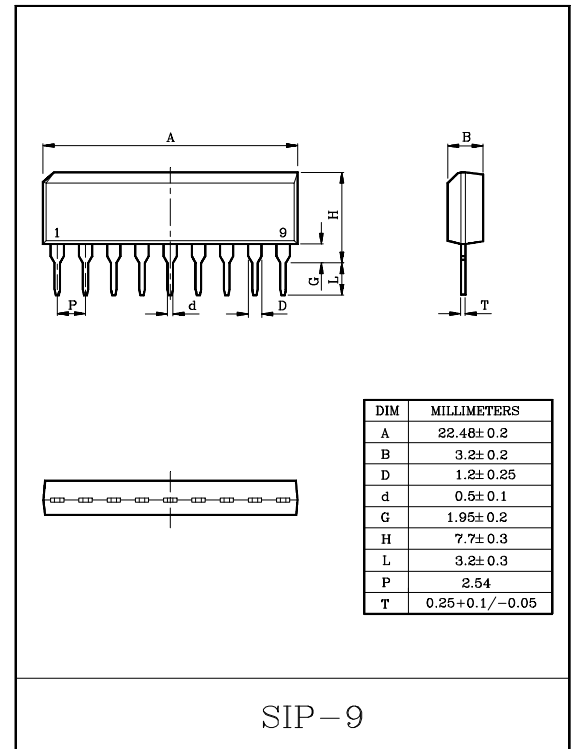

BLOCK DIAGRAM

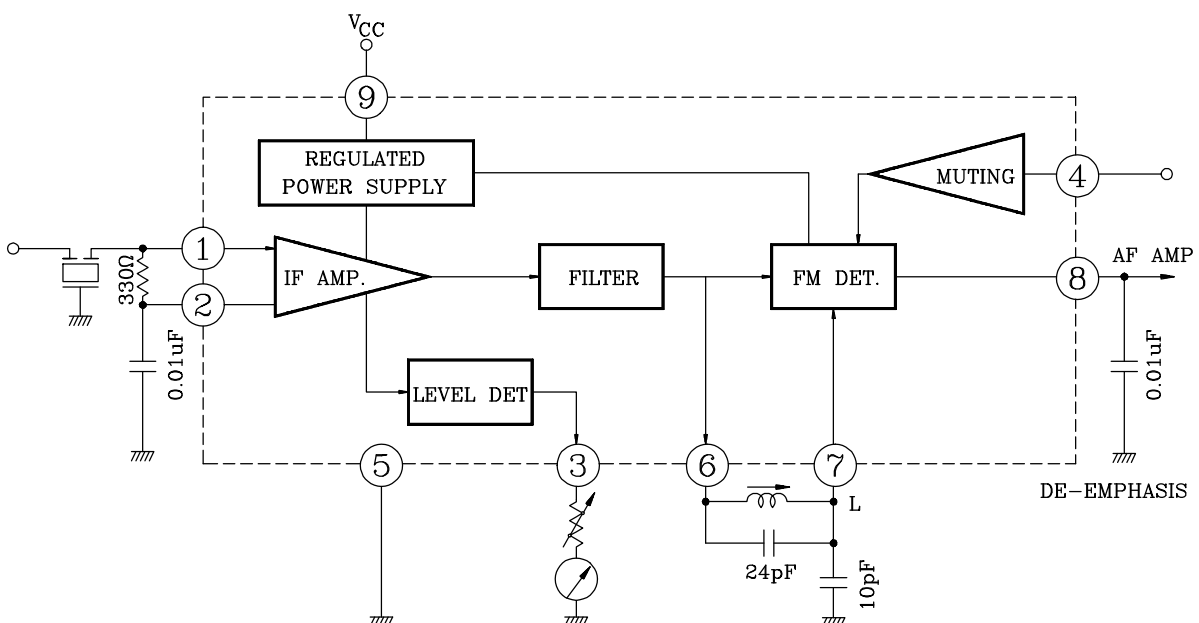

KIA6003S

ELECTRICAL CHARACTERISTICS ($V_{CC}=12V$, $f=10.7MHz$, $f_m=400Hz$, $T_a=25^\circ C$)

CHARACTERISTIC		SYMBOL	TEST CIRCUIT	TEST CONDITION	MIN.	TYP.	MAX.	UNIT
Supply Current		I_{CC}	1	$V_{IN}=0$	10	14	18	mA
Input Limiting Voltage		$V_{IN(lim)}$	1	$\Delta f = \pm 75kHz$ dev. -3dB LIMITING	-	50	55	dB μV
AM Rejection Ratio		AMR	1	FM: $\Delta f = \pm 75kHz$ dev. AM: 30% Mod. $V_{IN}=80dB\mu V$	-	50	-	dB
Recovered Output Voltage		V_{OD}	1	$\Delta f = \pm 75kHz$ dev. $V_{IN}=80dB\mu V$	300	500	700	mV _{rms}
Total Harmonic Distortion		THD	1	$\Delta f = \pm 22.5kHz$ dev. $V_{IN}=80dB\mu V$	-	0.1	-	%
Signal to Noise Ratio		S/N	1	$\Delta f = \pm 75kHz$ $V_{IN}=80dB\mu V$	-	75	-	dB
Muting Attenuation		MA	1	$\Delta f = \pm 75kHz$ dev. $V_{IN}=80dB\mu V$, $V_4=0$	-	70	-	dB
Meter Drive Voltage		$V_{3(Max)}$	1	$V_{IN}=110dB\mu V$	-	4	-	V
Input Impedance	Parallel Input Resistance	r_{ip}	-	$f=10.7MHz$, ①pin-GND	-	5	-	k Ω
	Parallel Input Capacitance	C_{ip}	-		-	-	4.5	-
Output Impedance	Parallel Output Resistance	r_{op}	-	$f=10.7MHz$, ⑥pin-GND	-	1.3	-	k Ω
	Parallel Output Capacitance	C_{op}	-		-	-	4	-
Output Resistance		R_O	-	$f=400Hz$, ⑧pin-GND	-	7.7	-	k Ω

Note : V_{OD} Rank (at $\Delta f = \pm 22.5kHz$)

RANK	MIN.	MAX.	UNIT
B	90	150	mV _{rms}
C	130	210	mV _{rms}

KIA6003S

TEST CIRCUIT 1

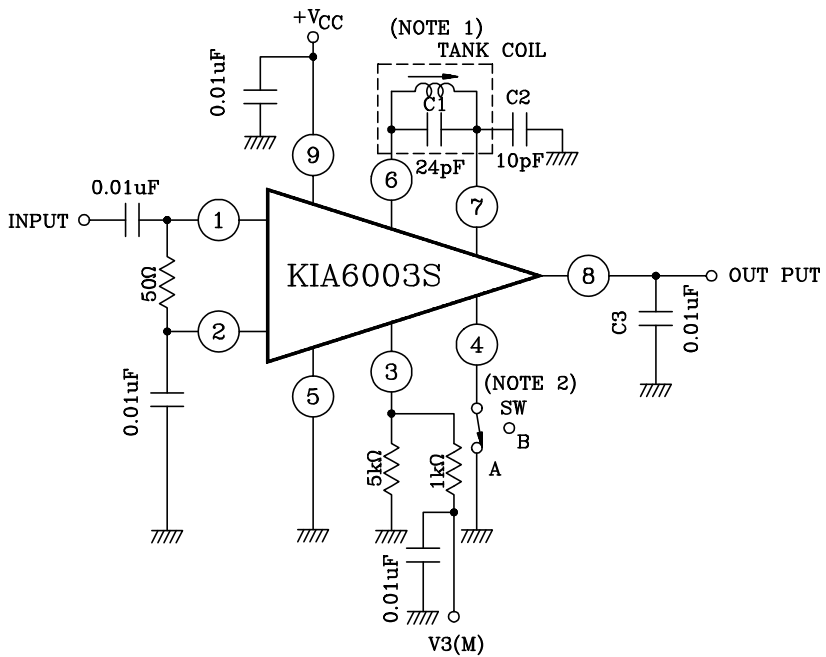

TANK COIL

WIRE	2 UEW 0.08mmφ
TURNS	21
QU	130±15%

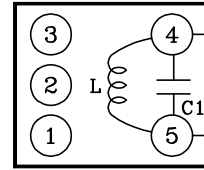

C1=24pF
C2=10pF

COVERED RESONANT FREQUENCY
10.7MHz±250kHz

$$f_0 = \left(\frac{1}{2\pi \sqrt{L (C_1 + \frac{C_2}{2})}} \right)$$

- (Note 1) Tuning coil is adjusted to make recovered output voltage maximum at f=10.7MHz.
- (Note 2) SW : To A for muting attenuation test only.

TEST CIRCUIT 2

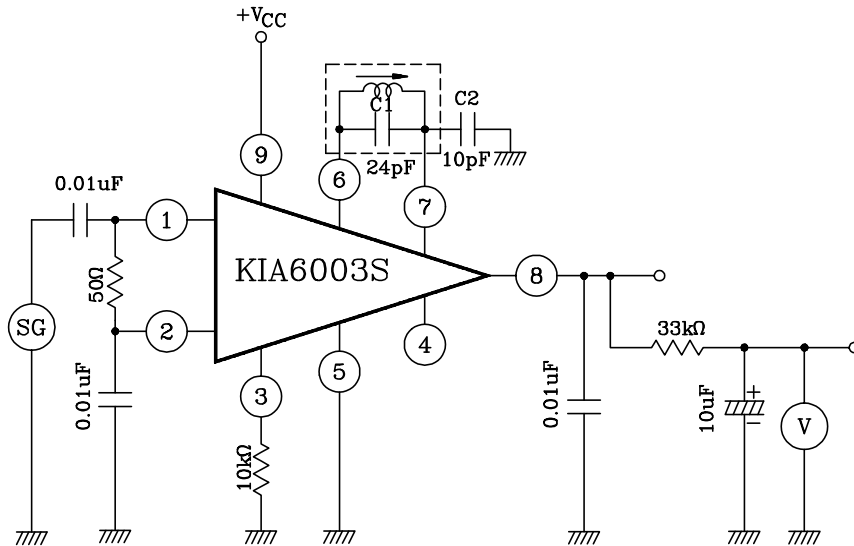

f_L: LOWER PEAK FREQUENCY
f₀: CENTER FREQUENCY
f_H: UPPER FREQUENCY

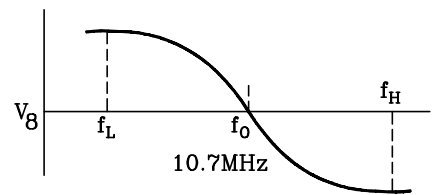

$$f_L = \frac{1}{2\pi \sqrt{L (C_1 + C_2)}}$$

$$f_0 = \frac{1}{2\pi \sqrt{L (C_1 + \frac{C_2}{2})}}$$

$$f_H = \frac{1}{2\pi \sqrt{LC_1}}$$

KIA6003S

